



INSTALLATION MANUAL

JUMBO VAN SHELVING

ATTENTION: PLEASE READ AND UNDERSTAND ALL INSTRUCTIONS AND WARNINGS BEFORE ASSEMBLING, INSTALLING OR USING THIS PRODUCT.

! DANGER

Danger of explosion. Do not use this product for storing or transporting flammables, explosives, hazardous materials, or hazardous waste, such as containers of gasoline, solvents, gun powder, dynamite, propane tanks, acetylene tanks and cutting torches. This product is only intended and safe for use in storing and transporting small tools, equipment and other similar materials. Any modifications made to, or unintended use of this product, could create a hazardous condition that can cause death, serious personal injury or property damage.

! WARNING

These instructions are to be followed using the parts and fasteners supplied for proper installation. Any modifications or improper installation of this product will create a hazardous condition that can cause property damage, serious personal injury or death.

– NOTICE –

Any modification or unintended use of this product shall immediately void all manufacturers warranties. Manufacturer disclaims all liability for injuries to persons or property resulting from any modification to, or unintended use of this product.









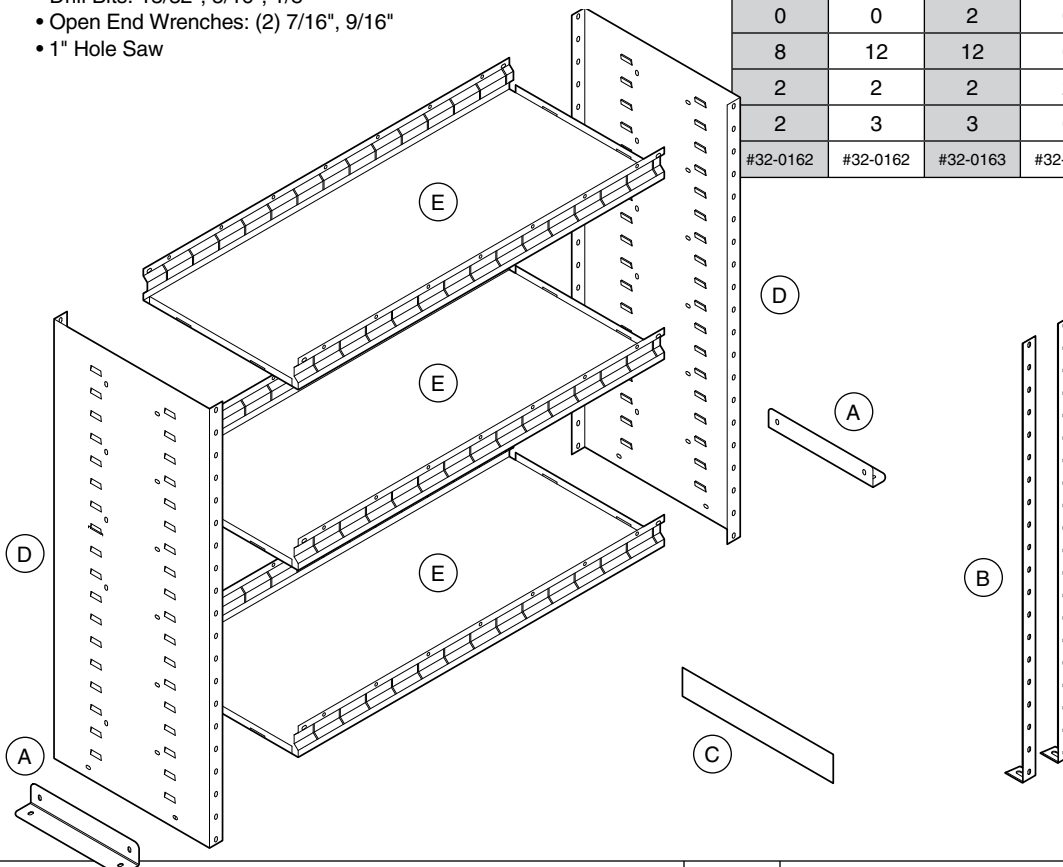

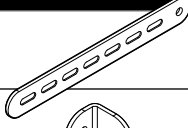



Approximate Assembly and Installation Time:
60-80 min. (1 to 1.3 hours) depending on number of shelf units and van equipment installation experience.

TOOLS REQUIRED

- Electric Drill
- Drill Bits: 13/32", 5/16", 1/8"
- Open End Wrenches: (2) 7/16", 9/16"
- 1" Hole Saw

8320	8380		8345	Parts List
8332	8381		8957	
8342	8383	8385	8958	
8352	8384	8391	8959	
	8390	8394		
	8393	8395		
2	2	2	2	A Floor Mounting Brackets
0	0	2	0	B Center Supports
8	12	12	0	C Shelf Dividers
2	2	2	2	D End Panels
2	3	3	0	E Shelves
#32-0162	#32-0162	#32-0163	#32-0183	Bolt Kit



NOTE: Depending on your application you may end up with extra hardware after installation is complete.	DESCRIPTION	BOLT KIT #32-0162 QTY.	BOLT KIT #32-0163 QTY.	BOLT KIT #32-0183 QTY.
	Mounting Straps	3	3	3
	Mounting Strap Angles	3	3	3
	1/4" Lock Washers	4	4	4
	1/4-20 Blind Fasteners	4	4	4
	1/4-20 x 5/8" Hex Head Bolts	10	10	10
	1/4-20 Serrated Nuts	12	12	0
	1/4-20 x 3/4" Hex Head Bolts	7	13	7
	1/4-20 x 1-1/4" Hex Head Bolts	4	6	4
	1/4-20 x 1/2" Hex Head Screws	12	12	0
	1/4-20 Nylon Lock Nuts	18	26	18
	1/4" Flat Washers	18	22	18
	Floor Mounting Spacers	4	6	4
	Blind Fastener Installation Tool	1	1	1
	1/4-20 x 2-1/4" Hex Head Black Bolt	1	1	1

KNAACK MANUFACTURING COMPANY LIMITED WARRANTY

This LIMITED WARRANTY is made by Knaack Manufacturing Company, 420 E. Terra Cotta Ave., Crystal Lake, Illinois to the original retail purchaser of KNAACK® Products.

KNAACK MANUFACTURING COMPANY WARRANTS THAT KNAACK PRODUCTS WILL BE FREE FROM DEFECTS IN MATERIAL AND WORKMANSHIP FOR A PERIOD OF THREE (3) YEARS FROM DATE OF PURCHASE BY THE ORIGINAL RETAIL PURCHASER.

If, before the expiration of the Warranty period, purchaser discovers that the KNAACK Product fails to fulfill the Warranty, purchaser shall contact Knaack Manufacturing Company to make arrangements for an inspection of the product. If Knaack Mfg. Co. determines a defect exists, Knaack Mfg. Co. shall, at its option and expense, repair or replace any defective part. All Warranty repairs shall be made by an authorized KNAACK Product dealer or Knaack Mfg. Co. approved service company.

This Warranty shall not apply if the KNAACK Product has been subjected to misuse, abnormal service or handling, improper maintenance, or alterations made by anyone other than a KNAACK Product dealer or a Knaack Mfg. Co. approved service company.

THE WARRANTY PRINTED ABOVE IS THE ONLY WARRANTY APPLICABLE TO THIS PURCHASE. ALL OTHER WARRANTIES, EXPRESS OR IMPLIED, INCLUDING BUT NOT LIMITED TO THE IMPLIED WARRANTIES OF MERCHANTABILITY AND FITNESS FOR A PARTICULAR PURPOSE ARE HEREBY DISCLAIMED.

KNAACK MANUFACTURING COMPANY SHALL NOT BE LIABLE FOR ANY INCIDENTAL OR CONSEQUENTIAL DAMAGES ARISING OUT OF ANY BREACH OF THIS WARRANTY. NOR SHALL THE DAMAGES EXCEED THE RETURN AMOUNT OF THE PURCHASE PRICE PAID BY THE ORIGINAL PURCHASER.

This Warranty is in lieu of all Warranties express or implied. The terms of this Warranty shall not be modified by any party, their successors or assigns. This Warranty gives you specific legal rights, and you may also have other rights which vary from state to state.

! CAUTION

Prior to drilling, so as not to cut or puncture fuel tanks, fuel lines, brake lines, electric wires, etc., check behind or underneath drilling and mounting locations.

To keep debris out of your eyes when checking the underside of the vehicle, or when drilling, always wear protective eyewear.

! WARNING

All floor mounting bolts near the fuel tank area should be installed from the underside of the vehicle, to guard against the fuel tank being punctured in the event of a collision. This would mean not using Blind Fasteners in this area. Holes in this area should be 5/16". Ensure ample space in roof ribs and sidewall ribs for mounting screws so as not to puncture exterior roof or wall.

- 1 After determining shelf spacing, assemble each Shelf to the End Panels by pushing the Shelf down, with the End Panel tab entering the pierced opening on the Shelf edge. Fasten the Shelves to the End Panels using four (4) 1/4-20 x 1/2" Hex Head Bolts and 1/4-20 Serrated Nuts.

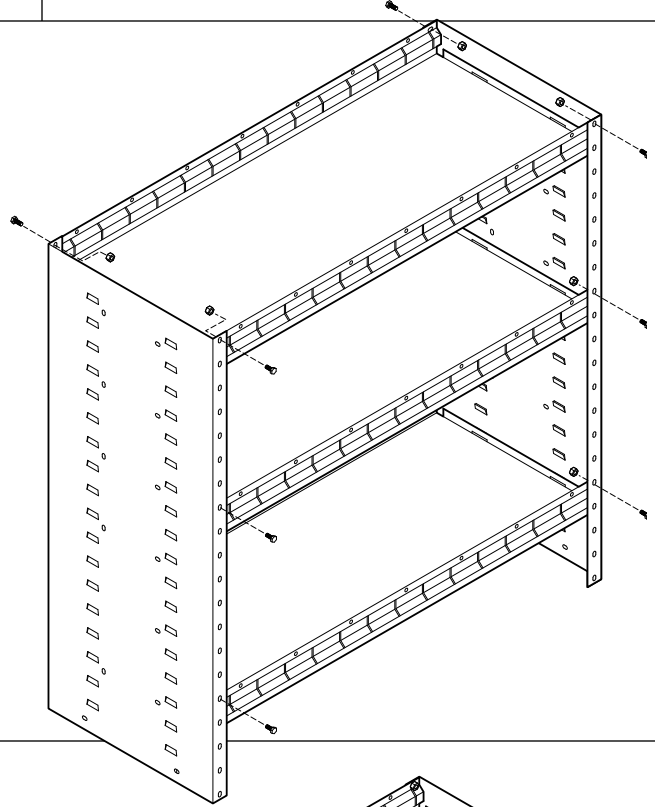
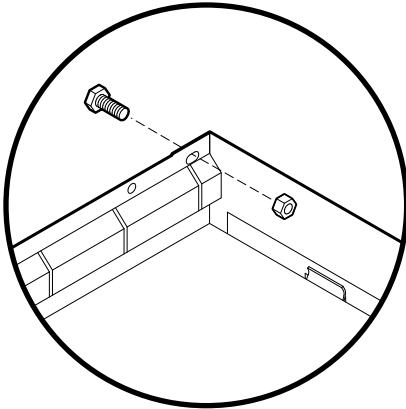

- 2 Attach the Floor Mounting Brackets to both ends of the unit using four (4) 1/4-20 x 3/4" Hex Head Bolts, 1/4" Flat Washers and 1/4-20 Nylon Lock Nuts.

NOTE: Floor Mounting Brackets can be installed on the outside or inside ends of the units. When installing two units side by side or connecting to a Bulkhead, only one Floor Mounting Bracket is required and should be installed inside.

If installing more than one shelf unit, holes in the end panels are provided for through-bolting into the next unit for greater rigidity.

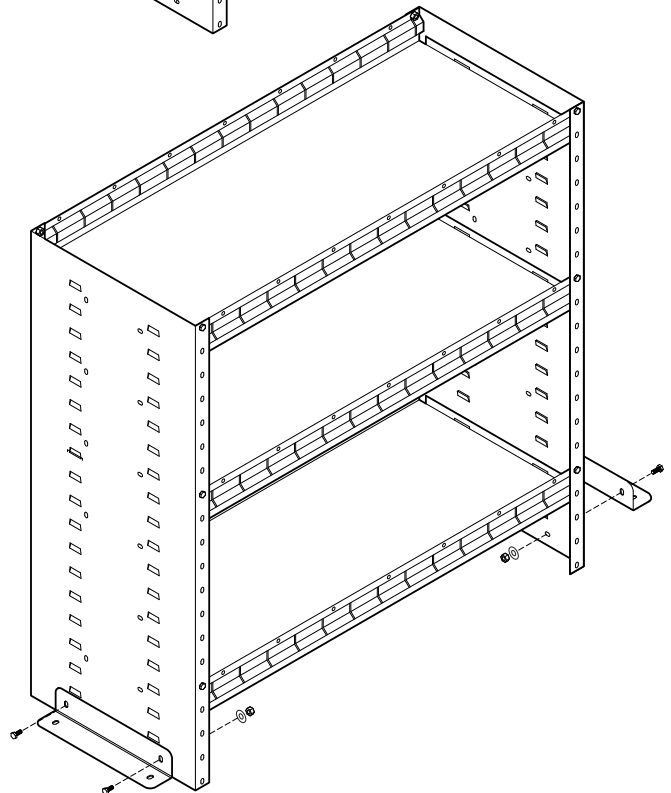
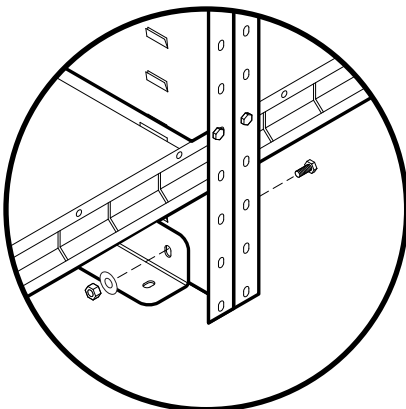

- 3 Place the unit into your selected position in the van, as close to the wall as possible. Mark the four floor mounting holes where the Floor Mounting Bracket comes in contact with the floor ribs.

NOTE: 60" & 69" SHELF UNITS: Center Support Legs have been added to these units to strengthen these shelves because of their length. (Go to step 6). If Center Supports are needed, then mark their floor mounting holes also. The Center Support can face towards the unit or away from the unit and should also contact the floor rib.

Remove the unit and pre-drill the floor mounting locations with an 1/8" drill bit, then re-drill the hole with a 5/16" drill bit. If there is a floor mat, then Floor Mounting Spacers are required. Cut the floor mat around the 5/16" holes with the 1" hole saw, allowing Floor Mounting Spacers to rest against the metal floor. **DO NOT DRILL THROUGH THE VAN FLOOR WITH THE HOLE SAW.**

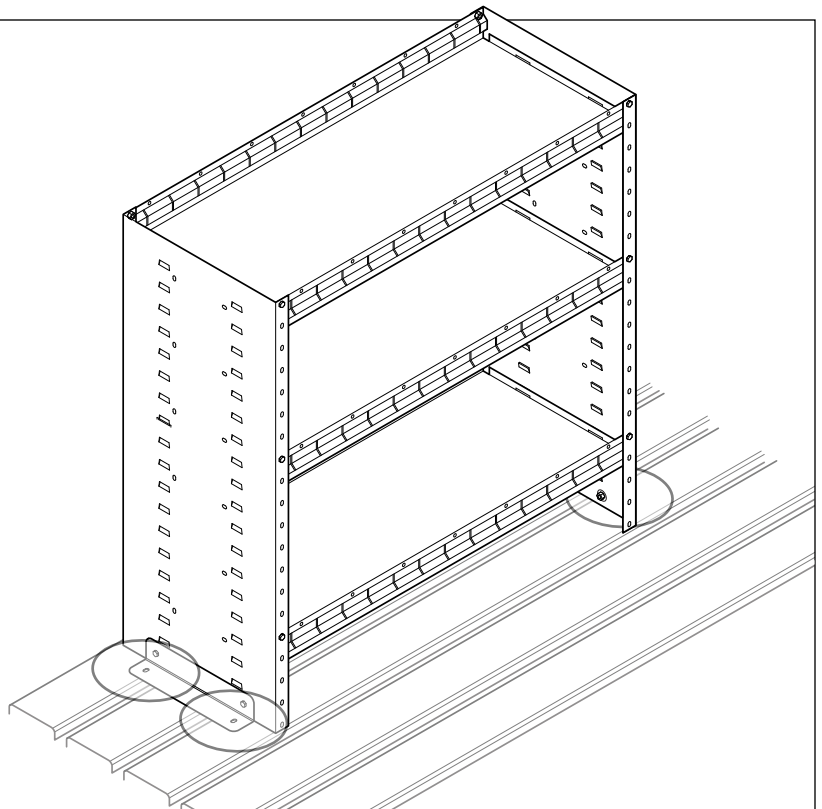

- 4 Move the unit back into position. Fasten unit to van floor using four (4) 1/4-20 x 1-1/4" Hex Head Bolts, 1/4" Flat Washers, Floor Mounting Spacers (if applicable), second set of 1/4" Flat Washers and 1/4-20 Nylon Lock Nuts. (See example bolting solutions below).

NOTE: One (1) Blind Fastener and Lock Washer have been provided in case through-bolting is impossible due to heat shields, floor channels, fuel lines, etc. If Blind Fastener installation is necessary, redrill the 5/16" mounting holes with 13/32" drill bit. See **INSTALLATION INSTRUCTIONS FOR BLIND FASTENERS** on page 6.

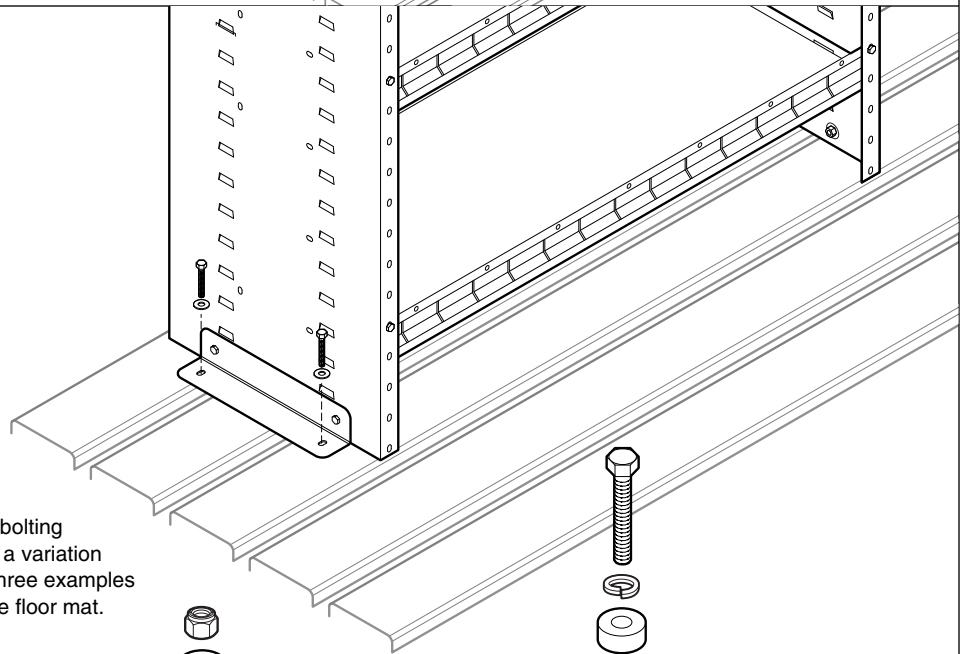

NOTE: The floor bolting solution could be a variation on any of these three examples with or without the floor mat.

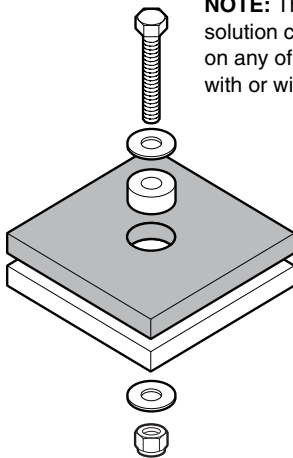

TOP DOWN INSTALLATION THROUGH FLOOR MAT AND VAN FLOOR

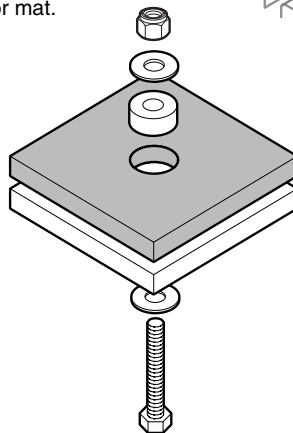

BOTTOM UP INSTALLATION THROUGH FLOOR MAT AND VAN FLOOR

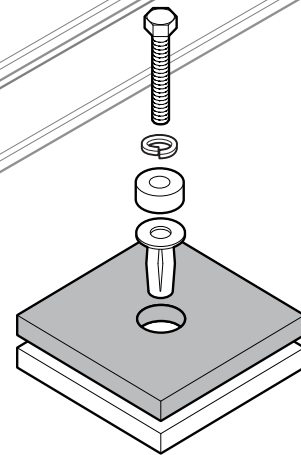

BLIND FASTENER INSTALLATION THROUGH FLOOR MAT AND VAN FLOOR (SEE PAGE 5)

- 5 Three (3) Mounting Straps and Mounting Strap Angles are provided. The Mounting Straps can be bent to any shape and/or used with the Mounting Angles. The Mounting Straps should be attached to the upper portion of the shelf unit in a manner that would minimize movement of the unit both front to rear and side to side. Attach the Mounting Straps to the shelf unit through existing holes (or drill new holes using a 5/16" drill bit) and fasten with three (3) 1/4-20 x 5/8" Hex Head Bolts and 1/4-20 Nylon Lock Nuts.

Fasten the other end of the Mounting Straps by installing two to three (2-3) Blind Fasteners in the wall or wall ribs at the Mounting Strap locations by pre-drilling 1/8" holes and then re-drill the holes with a 13/32" drill bit. Set the Blind Fasteners in the holes per the INSTALLATION INSTRUCTIONS FOR BLIND FASTENERS on page 6.

Realign the Mounting Straps/Mounting Strap Angles on top of the Blind Fasteners and secure them to the wall or wall rib using two to three (2-3) 1/4-20 x 3/4" Hex Head Bolts and 1/4" Lock Washers.

INSTALLATION IS COMPLETE.

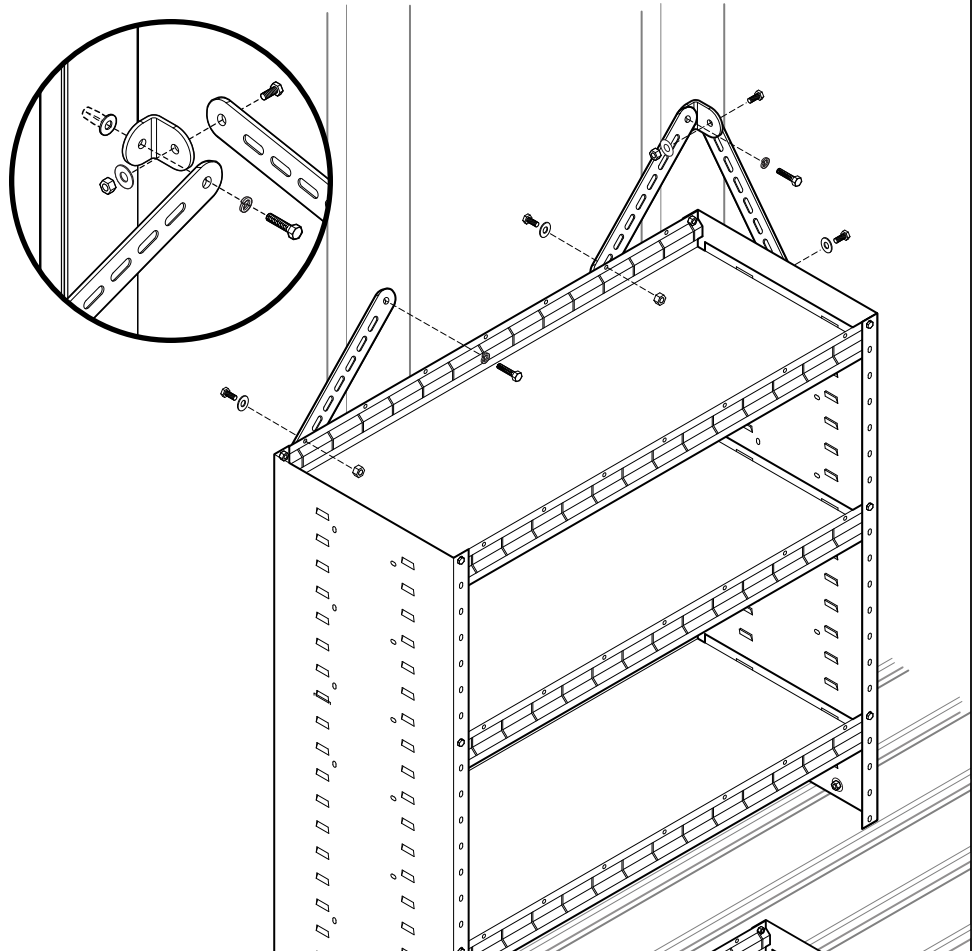

- 6 **60" & 69" SHELF UNITS:** Fasten the Support Leg(s) in the center of the Shelf using three (3) 1/4-20 x 3/4" Hex Head Bolts, and 1/4-20 Nylon Lock Nuts.

Return to step 3.

NOTE: If installing doors on these units, the Support Leg will need to be installed off-center on the shelf. Positioning of the Support Leg can easily be found by holding the door in position on the shelf. The notched out area of the hinge is where to locate the Support Leg.

A second leg can also be fastened to the back of the unit.

NOTE: The Center Support Leg may need to be trimmed depending on application. If the Support Leg is cut, remove burrs and apply paint.

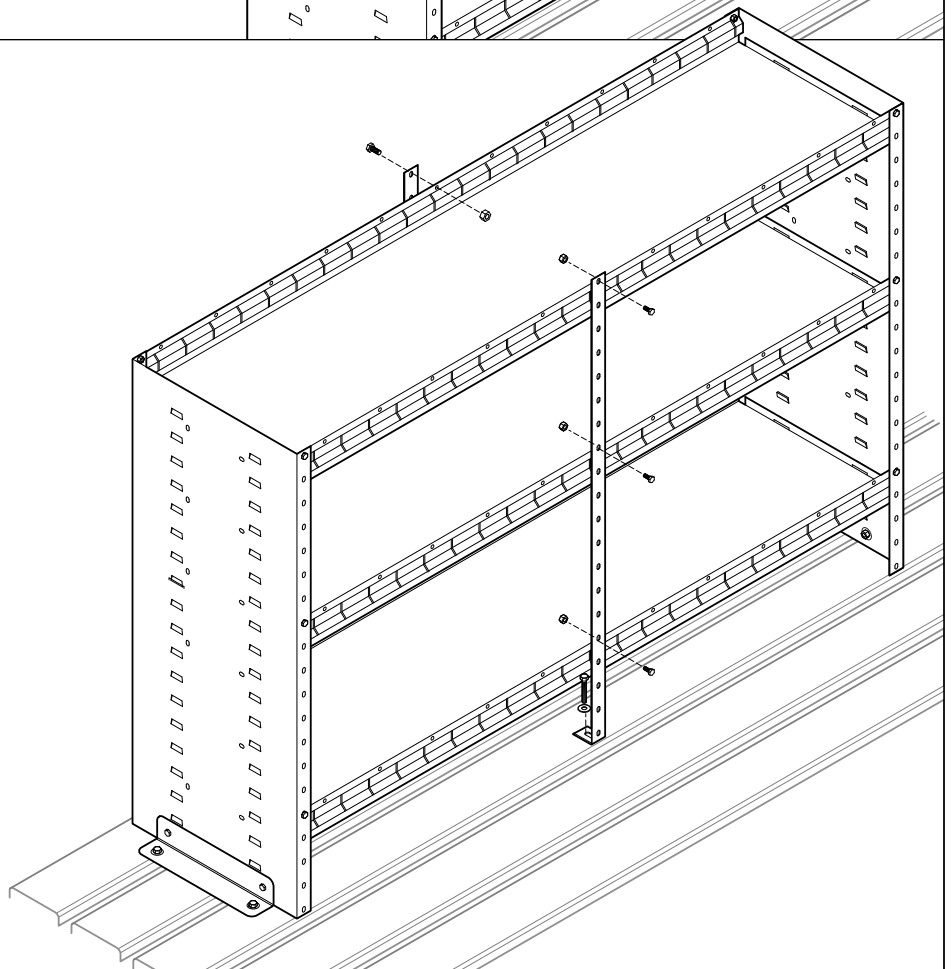

7 Insert the Shelf Dividers into the shelf slots.

NOTE: The side panels of the units have pre-punched holes conveniently located for installation of accessory items or to fasten to other shelf units for additional strength. Extra 1/4-20 x 5/8" bolts and lock nuts have been provided in the bolt kit for this purpose.

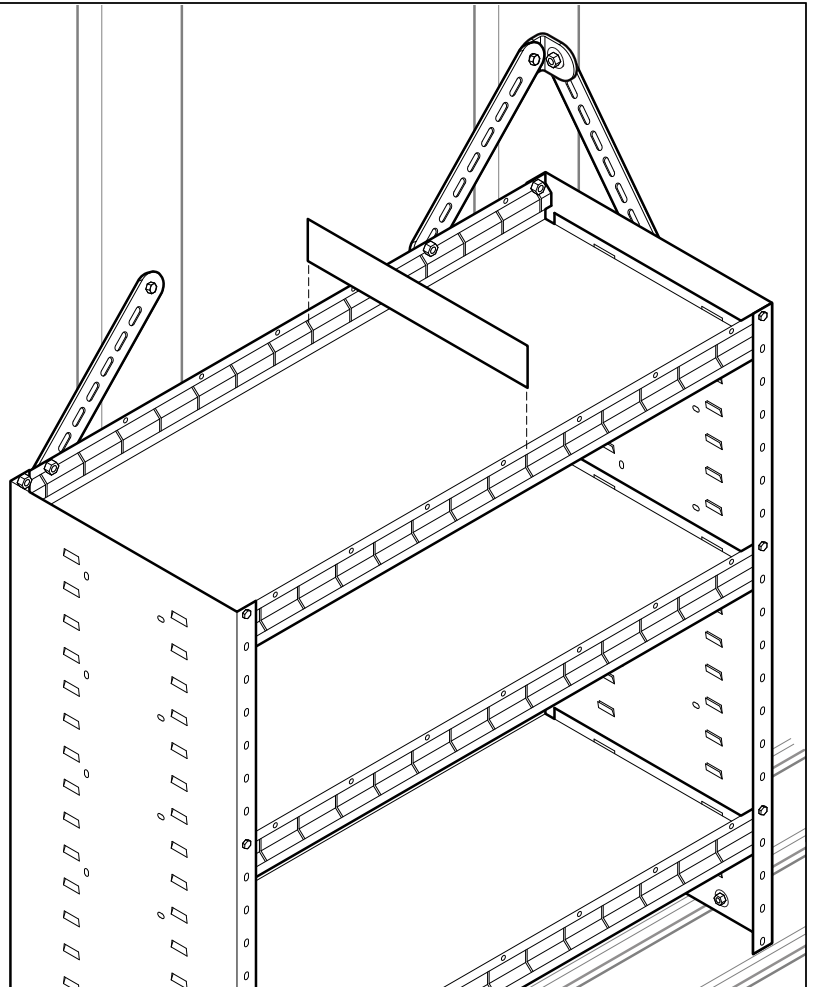

! WARNING

Prior to drilling, so as not to cut or puncture fuel tanks, fuel lines, brake lines, electric wires, etc., check behind or underneath drilling and mounting locations.

! CAUTION

To keep debris out of your eyes when checking the underside of the vehicle, or when drilling, always wear protective eyewear.

Place a drop of oil on the black oxide bolt before assembling as shown on right. Place the Blind Fastener in the hole and use a 7/16" wrench to tighten black hex bolt until the Blind Fastener is fully seated. When setting black hex bolt, it will start out hard. As the Blind Fastener "bulbs" out it will get easier, until it bottoms out or sets. Make sure the Blind Fastener and Installation Tool do not turn during installation.

INSTALLATION INSTRUCTIONS FOR BLIND FASTENERS

