



**advanced FLOW engineering**

**Instruction Manual** P/N: 77-43020

Make: **Ford** Model: **F-250/F-350/F-450** Year: **2017** Engine: **V8-6.7L (td) Power Stroke**



- Please read the entire instruction manual before proceeding.
- Ensure all components listed are present.
- If you are missing any of the components, call customer support at 951-493-7100.
- Ensure you have all necessary tools before proceeding.
- Do not attempt to work on your vehicle when the engine is hot.
- Disconnect the negative battery terminal before proceeding.
- Retain factory parts for future use.

Label	Qty.	Description	Part Number
A	1	Module	R77-43020
B	1	LED Switch	05-70005
C	2	Velcro (2 Inches)	05-01244
D	4	Cable Ties	05-60167

Note: Legal in California for use on race vehicles only. The use of this device on vehicles used on public streets or highways is strictly prohibited in California and others states that have adopted California emission regulations.

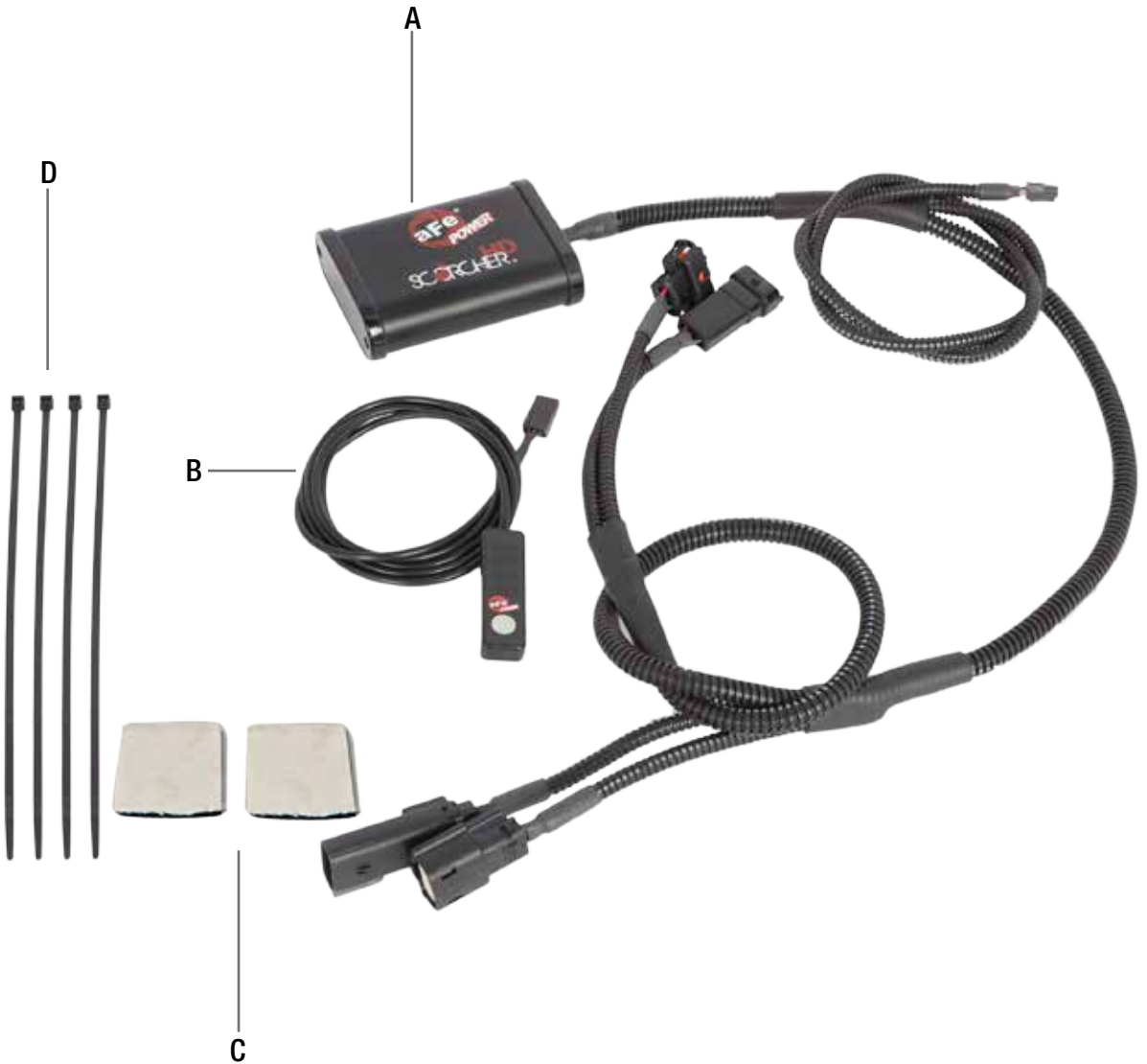

**Figure A****Refer to Figure A for Steps 1-2.**

Step 1: Locate the MAP sensor (1). The MAP sensor is on the top of the intake manifold next to a set of wires.

Step 2: Locate the fuel pressure sensor (2). It is accessible between the intercooler tube and radiator hose; at the end of the common fuel rail. The common fuel rail runs alongside the valve cover.



Figure B

**Refer to Figure B for Steps 3-4.**

Step 3: Disconnect the MAP sensor.

Step 4: Locate the MAP sensor jumper harness on the aFe module. This is the longer harness with a white cable on both connectors. Plug the male connector of the module to the female connector of engine harness, then the female connector of the module to the stock map sensor of the engine.

**Note: Make sure connections are fully engaged. Usually, connectors make a snapping sound**



**Refer to Figures C for Steps 5-6.**

Step 5: Locate and disconnect the fuel pressure sensor, on the driver's side of the engine (3).

Step 6: Locate the fuel pressure sensor jumper harness on the aFe module. This is the shorter harness with a red cable on both connectors. Plug the male connector of the module to the female connector of engine harness, then the female connector of the module to the stock fuel pressure sensor of the engine.

**Note: If there is a white plastic insert (4) on the OE harness connector, you will need to remove it.**





Figure D

**Refer to Figure D for Step 7.**

Step 7: Carefully detach the cover below the steering wheel to allow the switch and cable through (5). Mount the Switch on an open, flat surface (6). Route the switch harness and re-attach cover below steering wheel.



Figure E

**Refer to Figure E for Step 8.**

Step 8: Route the switch cable through firewall and into the engine bay (7). Follow the main harness through the grommet into the firewall. Plug the end of the cable to the module.



**Figure F****Refer to Figure F for Step 9.**

Step 9: Mount the module in a safe location, using the supplied Velcro strip. Then, secure the wires and module away from any extreme heat and moving parts, with the provided ties. Make sure all connections are secured and fully engaged.

**Figure G****Refer to Figure G for Step 10.**

Step 10: When turning on the vehicle, the switch will go through the light. It will stop at its last setting. The LED on the switch represents the different level of power.

- Green LED: Stock
- Yellow LED: Sport
- Orange LED: Sport+
- Red LED: Race

Use the grey button to select the desired setting. Power adjustments can be done at any moment.

Thank you for choosing aFe POWER!

Page left blank intentionally



Page left blank intentionally

Page left blank intentionally

**Cold Air Intake System**



P/N: 50-73006 (P10R)  
51-73006 (PDS)

**Air Intake System Scoop**



P/N: 54-73006-S

**Rear Differential Cover**



P/N: 46-70022-WL (w/ Oil)  
46-70022 (Blk)  
46-70020 (RAW)

**OER Air Filter**



P/N: 10-10139 (P5R)  
11-10139 (PDS)  
71-10139 (PG7)

To purchase any of the items above, view airflow charts, dyno graphs, photos, and video please go to [aFepower.com](http://aFepower.com).

# Warranty

## General Terms:

- aFe warrants their products to be free from manufacturer's defects due to workmanship and material.
- This warranty applies only to the original purchaser of the product and is non-transferrable.
- Proof of purchase of the aFe product is required for all warranty claims.
- Warranty is valid provided aFe instructions for installation and/or cleaning were properly followed.
- Proper maintenance with regular inspections of product is required to insure warranty coverage.
- Damage due to improper installation, abuse, unauthorized repair or alteration is not warranted.
- Incidental or consequential damages or cost, including installation and removal of part, incurred due to failure of aFe product is not covered under this warranty.
- All warranty is limited to the repair and/or replacement of the aFe part. To request Return Goods Authorization ("RGA"), email [RGA@afepower.com](mailto:RGA@afepower.com) or call (951)493-7100. Upon receipt of the RGA, you must return the product to the address provided in the RGA, freight prepaid and accompanied with a dated proof of purchase and the RGA. Upon receipt of the defective product and upon verification of proof of purchase, aFe will either repair or replace the defective product within a reasonable time, not to exceed thirty days.

<b>Product Category</b>	<b>P/N Prefix</b>	<b>Warranty duration</b>
Direct OE Replacement Filters	10, 11, 30, 31, 71, 73	Life of the vehicle
Racing Filters	18	1 year
Universal	21, 24, 72, TF	2 years
Air Intake Systems	50, 51, 54, 55, 75, TR, TA, TL	2 years
Exhaust Systems	49	2 years
Intercoolers & Intercooler Tubes	46-2	2 years
Intake Manifolds	46-1	2 years
Differential Cover	46-7	Life of the vehicle
Exhaust Manifolds	46	2 years
Throttle Body Spacers	46-3	2 years
Fluid Filters	44	90 days
Pre-Filters	28	2 years
Heavy Duty OE Replacement	70	2 years
PowerSports OE Replacement	81, 87	2 years
PowerSports Intake Systems	85	2 years
Tuners	77	Contact aFe

No other warranty expressed or implied applies nor is any person or advanced FLOW engineering authorized to assume any other warranty. Some States do not allow the exclusion or limitation of incidental or consequential damages or do not allow limitations on how long an implied warranty lasts, so the above limitations or exclusions may not apply to you. This warranty gives you specific legal rights, and you may also have other rights which vary from State to State.



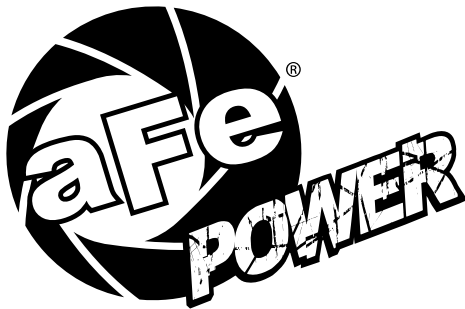

**advanced FLOW engineering, inc.**  
252 Granite Street Corona, CA 92879  
TEL: 951.493.7100  
E-Mail: [Tech@aFepower.com](mailto:Tech@aFepower.com)



**MOMENTUM** **HD**

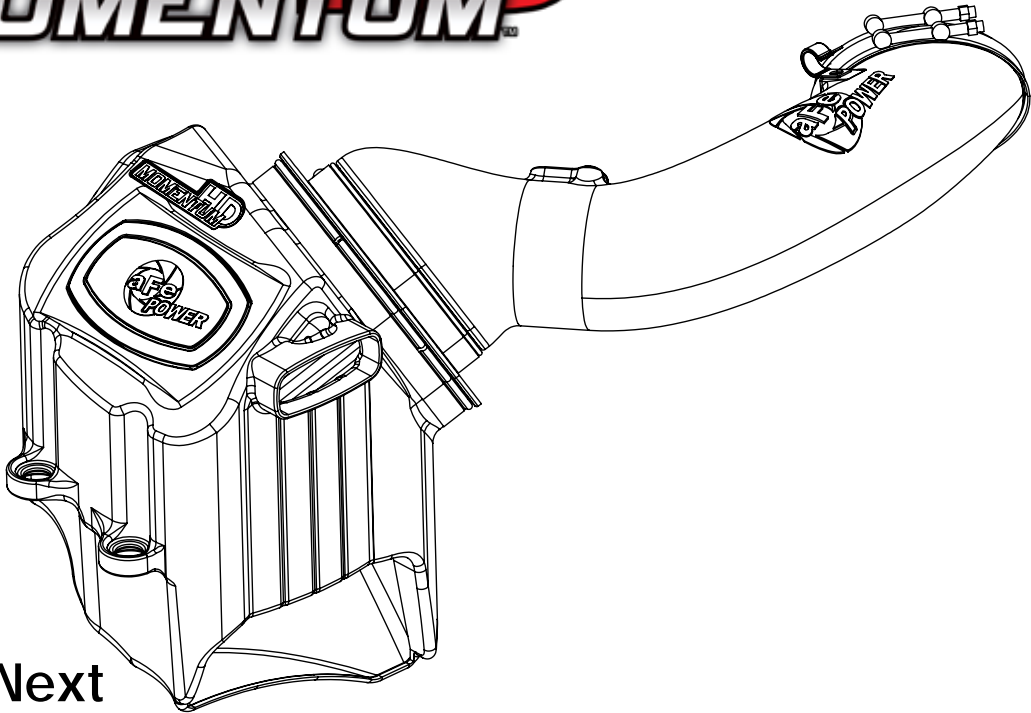

The Next  
Generation  
of Intakes

**advanced FLOW engineering** Momentum Air Intake

**Instruction Manual** P/N: 50-73006 / 51-73006

---

Make: **Ford** Model: **Super Duty F-250/F-350** Year: **2017** Engine: **V8-6.7L (td) Power Stroke**



- Please read the entire instruction manual before proceeding.
- Ensure all components listed are present.
- If you are missing any of the components, call technical support at 951-493-7100 or e-mail [tech@afepower.com](mailto:tech@afepower.com).
- Ensure you have all necessary tools before proceeding.
- Do not attempt to work on your vehicle when the engine is hot.
- Disconnect both the negative battery terminal before proceeding.

## Retain factory parts for future use.

Label	Qty.	Description	Part Number
A1	1	Pro 10R (Blue Media)	20-91061
A2	1	Pro DRY S (Gray Media)	21-91061
B	1	Tube	05-73006B1
C	1	Housing	05-73006B2
D	1	Plug, Urethane	05-01225
E	1	Coupling, Silicone Hump	05-01204
F	1	Washer: M6	03-50070
G	2	Screw, Torx: M4	03-50491
H	1	Screw, Hex Hd: M6	03-50057
I	1	Fixing Clamp, 3/4"	03-50234
J	2	Clamp, T-bolt (4-13-16" - 5-1/8)	03-50261
K	1	Clamp, T-bolt (8-5/16" - 8-5/8")	03-50267

Installation will require the following tools:  
7mm, 8mm, 10mm, 7/16 nut driver or socket and extension.

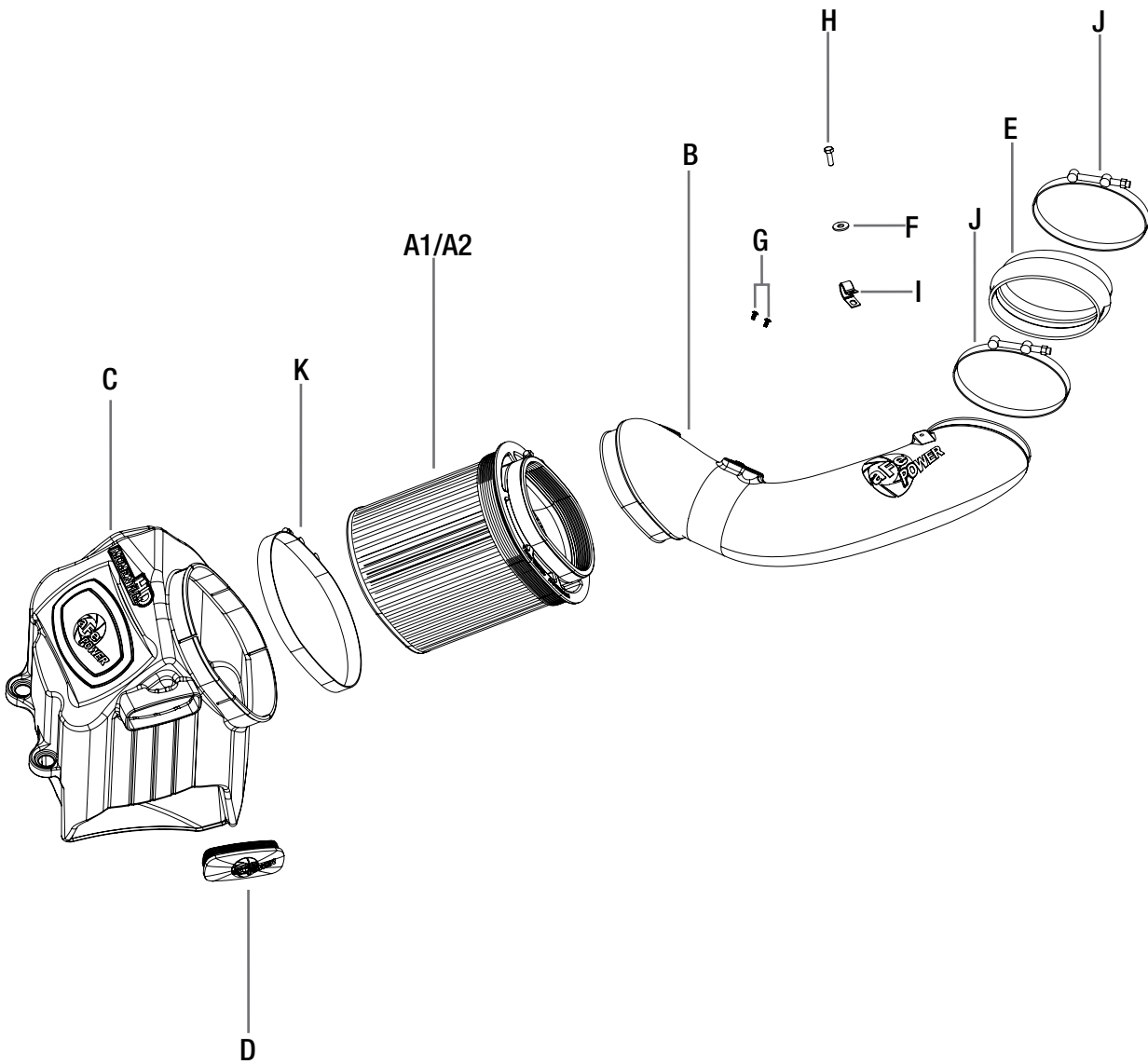



Figure A

**Refer to Figure A for Step 1**

Step 1: Remove the two 8mm bolts securing the OE filter housing, and loosen the two clamps on the OE tube.



Figure B

**Refer to Figure B for Step 2**

Step 2: Push the small hoses out of the way on the OE tube, and remove the tube.



Figure C

**Refer to Figure C for Steps 3-4**

Step 3: Slide back the red locking tab on the bottom side of the MAF sensor connector, and then disconnect the sensor.

Step 4: Remove the OE air box, pulling in an upward motion.





Figure D

**Refer to Figure D for Steps 5-6**

Step 5: Remove the factory grommets from the OE air box and install on the Momentum HD housing.

Step 6: Slide the filter into the housing and install provided T-bolt clamps. Tighten only the larger T-bolt clamp.



Figure E

**Refer to Figure E for Step 7**

Step 7: Install the Momentum HD housing into the vehicle by pushing it in to the factory grommet.



Figure F

**Refer to Figure F for Steps 8-10**

Step 8: Transfer the factory filter minder and grommet (1) on to the Momentum HD tube.

Step 9: Transfer the MAF sensor (2) from the OE housing to the Momentum HD tube using the provided screws.

Step 10: Install silicone coupling (3) and T-bolt clamps (4) onto the small end of the tube. Do not tighten clamps.



**Figure G**

**Refer to Figure G for Steps 11-15**

Step 11: Install Momentum HD tube by first sliding the coupling over the turbo inlet. Connect the other end to the air filter.

Step 12: Tighten all clamps.

Step 13: Reconnect the MAF sensor (5).

Step 14: Secure hose to the tube with provided fixing clamp (6), 10mm bolt (7) and washer (8).

Step 15: Reinstall the factory two 8mm bolts removed in Step 1 securing the air box.



Figure H

### **Refer to Figure H for Steps 16-18**

Step 16: If you have purchased the aFe air scoop (P/N: 54-73006-S), install it referring to its install instruction sheet.

Step 17: If you don't have the air scoop, you have the option to close off the extra air inlet with the furnished plug or to keep it open.

- Without the plug installed, the aFe Power intake will capture the maximum air available. More airflow offers more power. Yet some of this air is picked up from inside the engine compartment and could be warmer air. Warmer air will affect the performance of the vehicle.
- The plug installed on the housing will block off any hot engine air entering the housing and make sure the coolest air available is directed into the engine. It will also reduce the noise of the intake.

Step 18: Verify all connection are secured. The installation is now completed.

**NOTE: Place enclosed CARB EO sticker on or near the device on a smooth, clean surface. EO identification label is required to pass the smog inspection.**



Page left blank intentionally

Page left blank intentionally



**Pro DRY S Air Filter**



P/N: 21-91061

**Pro 10R Air Filter**



P/N: 20-91061

**Pro-GUARD 7 Air Filter**



P/N: 72-91059

**Pro DRY S Restore Kit**



P/N: 90-59999

**Blue Squeeze Restore Kit**



P/N: 90-50501

**Gold Squeeze Restore Kit**



P/N: 90-50500

**Pre-Filter**



P/N: 28-10283

**Dynamic Air Scoop**



P/N: 54-73006-S

**SCORCHER HD Module**



P/N: 77-43020

**DPF-Back Exhaust System**



P/N: 49-43090-B (Blk Tip)  
49-43090-P (Pol Tip)

**DP-Back Exhaust System**



P/N: 49-03093

**Rear Differential Cover**



P/N: 46-70022-WL (W/ Oil)  
46-70022 (Black)

To purchase any of the items above, view airflow charts, dyno graphs, photos, and video; please go to [aFepower.com](http://aFepower.com).

# Warranty

## General Terms:

- aFe warrants their products to be free from manufacturer's defects due to workmanship and material.
- This warranty applies only to the original purchaser of the product and is non-transferrable.
- Proof of purchase of the aFe product is required for all warranty claims.
- Warranty is valid provided aFe instructions for installation and/or cleaning were properly followed.
- Proper maintenance with regular inspections of product is required to insure warranty coverage.
- Damage due to improper installation, abuse, unauthorized repair or alteration is not warranted.
- Incidental or consequential damages or cost, including installation and removal of part, incurred due to failure of aFe product is not covered under this warranty.
- All warranty is limited to the repair and/or replacement of the aFe part. To request Return Goods Authorization ("RGA"), email [RGA@afepower.com](mailto:RGA@afepower.com) or call (951)493-7100. Upon receipt of the RGA, you must return the product to the address provided in the RGA, freight prepaid and accompanied with a dated proof of purchase and the RGA. Upon receipt of the defective product and upon verification of proof of purchase, aFe will either repair or replace the defective product within a reasonable time, not to exceed thirty days.

<b>Product Category</b>	<b>P/N Prefix</b>	<b>Warranty duration</b>
Direct OE Replacement Filters	10, 11, 30, 31, 71, 73	Life of the vehicle
Racing Filters	18	1 year
Universal	21, 24, 72	2 years
Air Intake Systems	50, 51, 54, 55, 75	2 years
Exhaust Systems	49	2 years
Intercoolers & Intercooler Tubes	46-2	2 years
Intake Manifolds	46-1	2 years
Differential Cover	46-7	Life of the vehicle
Exhaust Manifolds	46	2 years
Throttle Body Spacers	46-3	2 years
Fluid Filters	44	90 days
Pre-Filters	28	2 years
Heavy Duty OE Replacement	70	2 years
PowerSports OE Replacement	81, 87	2 years
PowerSports Intake Systems	85	2 years

No other warranty expressed or implied applies nor is any person or advanced FLOW engineering authorized to assume any other warranty. Some States do not allow the exclusion or limitation of incidental or consequential damages or do not allow limitations on how long an implied warranty lasts, so the above limitations or exclusions may not apply to you. This warranty gives you specific legal rights, and you may also have other rights which vary from State to State.



**advanced FLOW engineering, inc.**

252 Granite Street Corona, CA 92879

TEL: 951.493.7155 • TECH: 951.493.7100

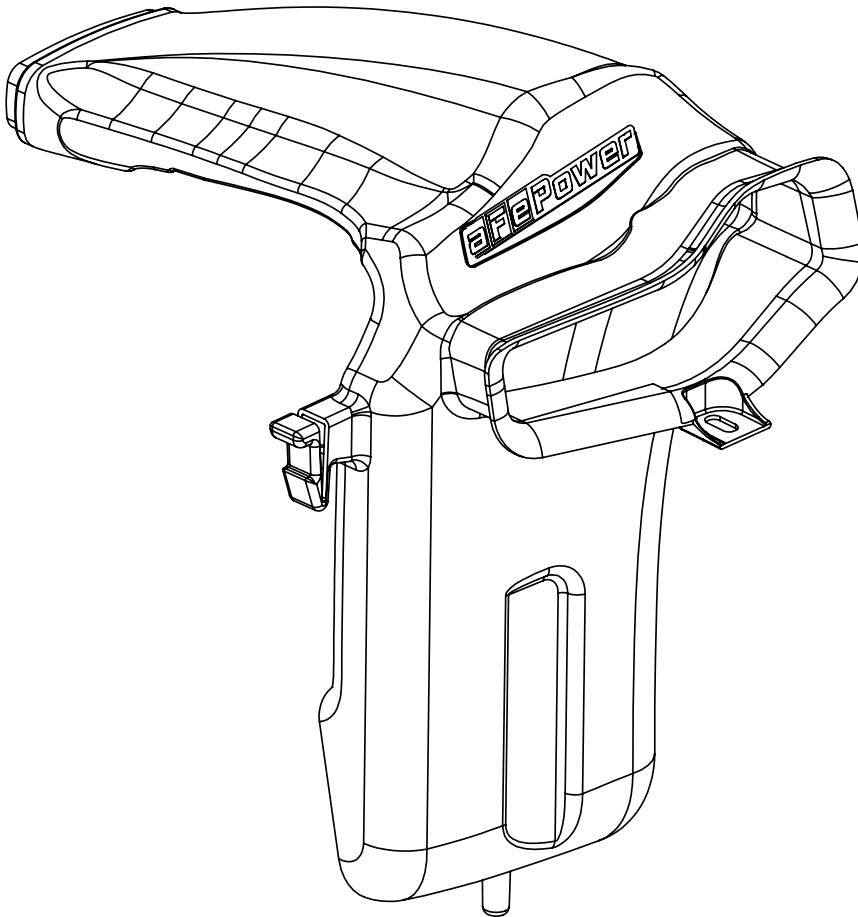
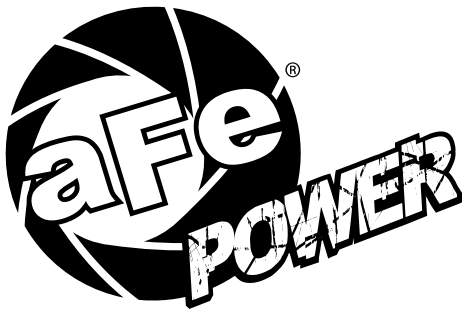

**advanced FLOW engineering**

**Instruction Manual** P/N: 54-73006-S

---

Make: **Ford** Model: **Super Duty F-250/F-350** Year: **2017** Engine: **V8-6.7L (td) Power Stroke**



- Please read the entire instruction manual before proceeding.
- Ensure all components listed are present.
- If you are missing any of the components, call customer support at 951-493-7100.
- Ensure you have all necessary tools before proceeding.
- Do not attempt to work on your vehicle when the engine is hot.



## Retain factory parts for future use.

Label	Qty.	Description	Part Number
A	1	Scoop, Rotomold	05-73006B3
B	1	Seal, Trim: 7/16" (8-1/2" in.)	05-00072

Installation will require the following tools:  
Panel popper tool.

Note: Legal in California for use on race vehicles only. The use of this device on vehicles used on public streets or highways is strictly prohibited in California and others states that have adopted California emission regulations.

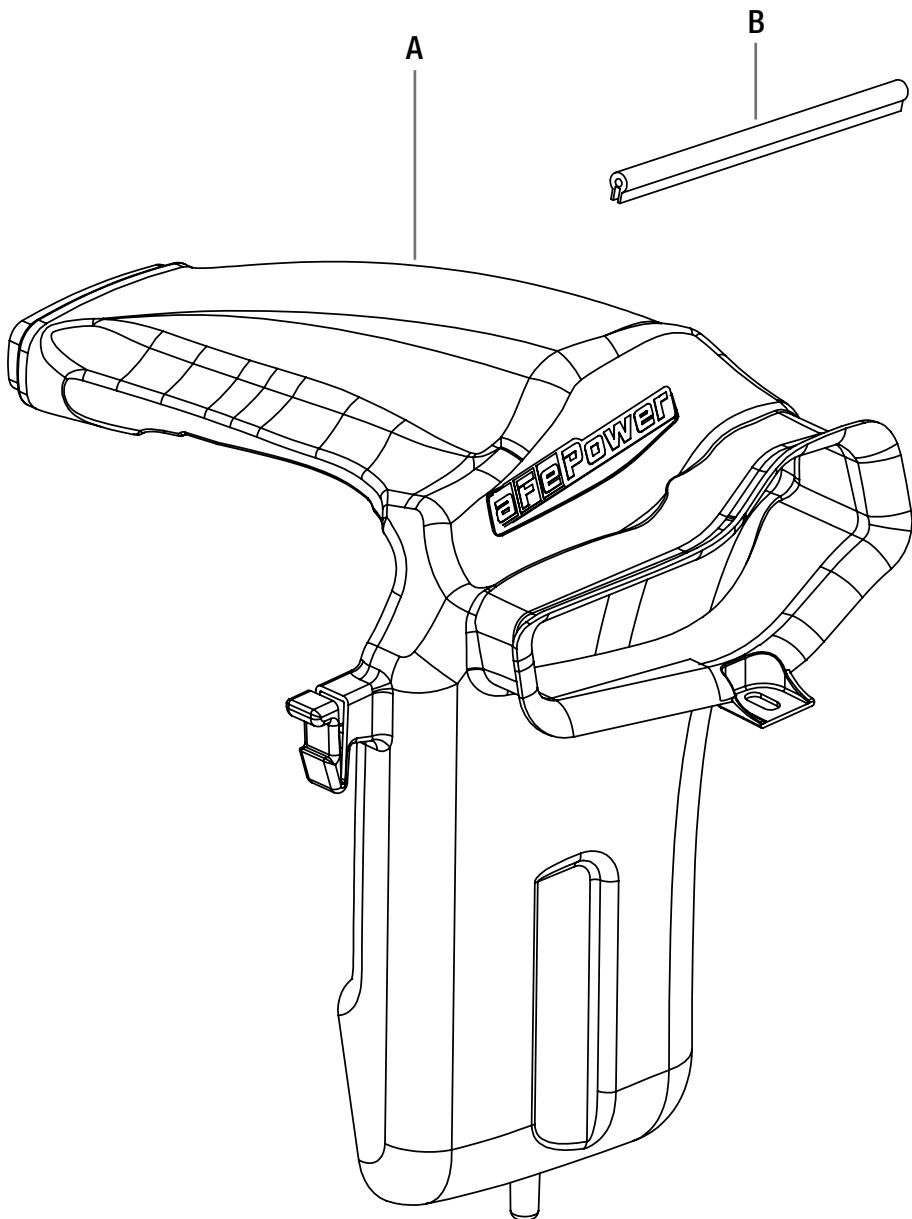



Figure A

**Refer to Figure A for Step 1**

Step 1: Remove the two push clips securing OE scoop.





Figure B

**Refer to Figure B for Step 2**

Step 2: Squeeze the two locking tabs inward and remove OE scoop by pulling in upward motion.



Figure C

**Refer to Figure C for Step 3**

Step 3: Install aFe scoop into Momentum HD housing and then push scoop down until the two tabs lock into place.

**NOTE: Make sure scoop is positioned behind the plastic OE radiator panel.**



Figure D

**Refer to Figure D for Steps 4-5**

Step 4: Replace the two OE push clips removed in Step 1.

Step 5: Install supplied trim seal along the top edge of scoop inlet.

Your installation is now complete. Thank you for choosing aFe POWER!



Page left blank intentionally

Page left blank intentionally



**Air Intake System**



P/N: 50-73006 (P10R)  
51-73006 (PDS)

**DPF-Back Exhaust System**



P/N: 49-43090-B (Blk Tip)  
49-43090-P (Pol Tip)

**DP-Back Exhaust System**



P/N: 49-03093

**Rear Differential Cover**



P/N: 46-70022-WL (W/ Oil)  
46-70022 (Black)

**SCORCHER HD Module**



P/N: 77-43020

**Engine Oil Cap**



P/N: 79-12006

To purchase any of the items above, view airflow charts, dyno graphs, photos, and video; please go to [aFepower.com](http://aFepower.com).

# Warranty

## General Terms:

- aFe warrants their products to be free from manufacturer's defects due to workmanship and material.
- This warranty applies only to the original purchaser of the product and is non-transferrable.
- Proof of purchase of the aFe product is required for all warranty claims.
- Warranty is valid provided aFe instructions for installation and/or cleaning were properly followed.
- Proper maintenance with regular inspections of product is required to insure warranty coverage.
- Damage due to improper installation, abuse, unauthorized repair or alteration is not warranted.
- Incidental or consequential damages or cost, including installation and removal of part, incurred due to failure of aFe product is not covered under this warranty.
- All warranty is limited to the repair and/or replacement of the aFe part. To request Return Goods Authorization ("RGA"), email [RGA@afepower.com](mailto:RGA@afepower.com) or call (951)493-7100. Upon receipt of the RGA, you must return the product to the address provided in the RGA, freight prepaid and accompanied with a dated proof of purchase and the RGA. Upon receipt of the defective product and upon verification of proof of purchase, aFe will either repair or replace the defective product within a reasonable time, not to exceed thirty days.

<b>Product Category</b>	<b>P/N Prefix</b>	<b>Warranty duration</b>
Direct OE Replacement Filters	10, 11, 30, 31, 71, 73	Life of the vehicle
Racing Filters	18	1 year
Universal	21, 24, 72, TF	2 years
Air Intake Systems	50, 51, 54, 55, 75, TR, TA, TL	2 years
Exhaust Systems	49	2 years
Intercoolers & Intercooler Tubes	46-2	2 years
Intake Manifolds	46-1	2 years
Differential Cover	46-7	Life of the vehicle
Exhaust Manifolds	46	2 years
Throttle Body Spacers	46-3	2 years
Turbochargers	46-6	2 years*
Fluid Filters	44	90 days
Pre-Filters	28	2 years
Heavy Duty OE Replacement	70	2 years
PowerSports OE Replacement	81, 87	2 years
PowerSports Intake Systems	85	2 years

No other warranty expressed or implied applies nor is any person or advanced FLOW engineering authorized to assume any other warranty. Some States do not allow the exclusion or limitation of incidental or consequential damages or do not allow limitations on how long an implied warranty lasts, so the above limitations or exclusions may not apply to you. This warranty gives you specific legal rights, and you may also have other rights which vary from State to State.

\*See turbocharger warranty for more info



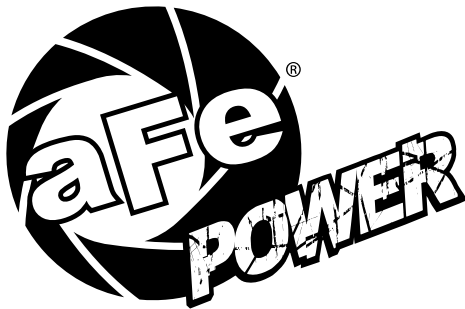

**advanced FLOW engineering, inc.**  
252 Granite Street Corona, CA 92879  
TEL: 951.493.7100