

11128**89-98 CHEVY & GEO TRACKER
89-98 SUZUKI SIDEKICK**

9/10/2012

GROSS LOAD CAPACITY WHEN USED AS A WEIGHT CARRYING HITCH: 2,000 LBS. TRAILER WEIGHT & 200 LBS. TONGUE WEIGHT.

*****DO NOT EXCEED VEHICLE MANUFACTURER'S RECOMMENDED TOWING CAPACITY.*******WARNING: ALL NON-TRAILER LOADS APPLIED TO THIS PRODUCT MUST BE SUPPORTED BY AUXILIARY STABILIZING STRAPS.****** FAILURE TO PROPERLY SUPPORT NON-TRAILER LOADS WILL VOID PRODUCT WARRANTY****

HAVING INSTALLATION QUESTIONS? CALL TECHNICAL SUPPORT AT 1-800-798-0813

Parts List			
ITEM	QTY	PART NUMBER	DESCRIPTION
1	8	CM-SP25	.250 x 1.38 x 1.50" ROUND HOLE SPACER
2	4	M12 - 1.25 x 40 HEX	HEX BOLT
3	4	FW12	FW, 12, ZP
4	4	1/2"	LOCK WASHER

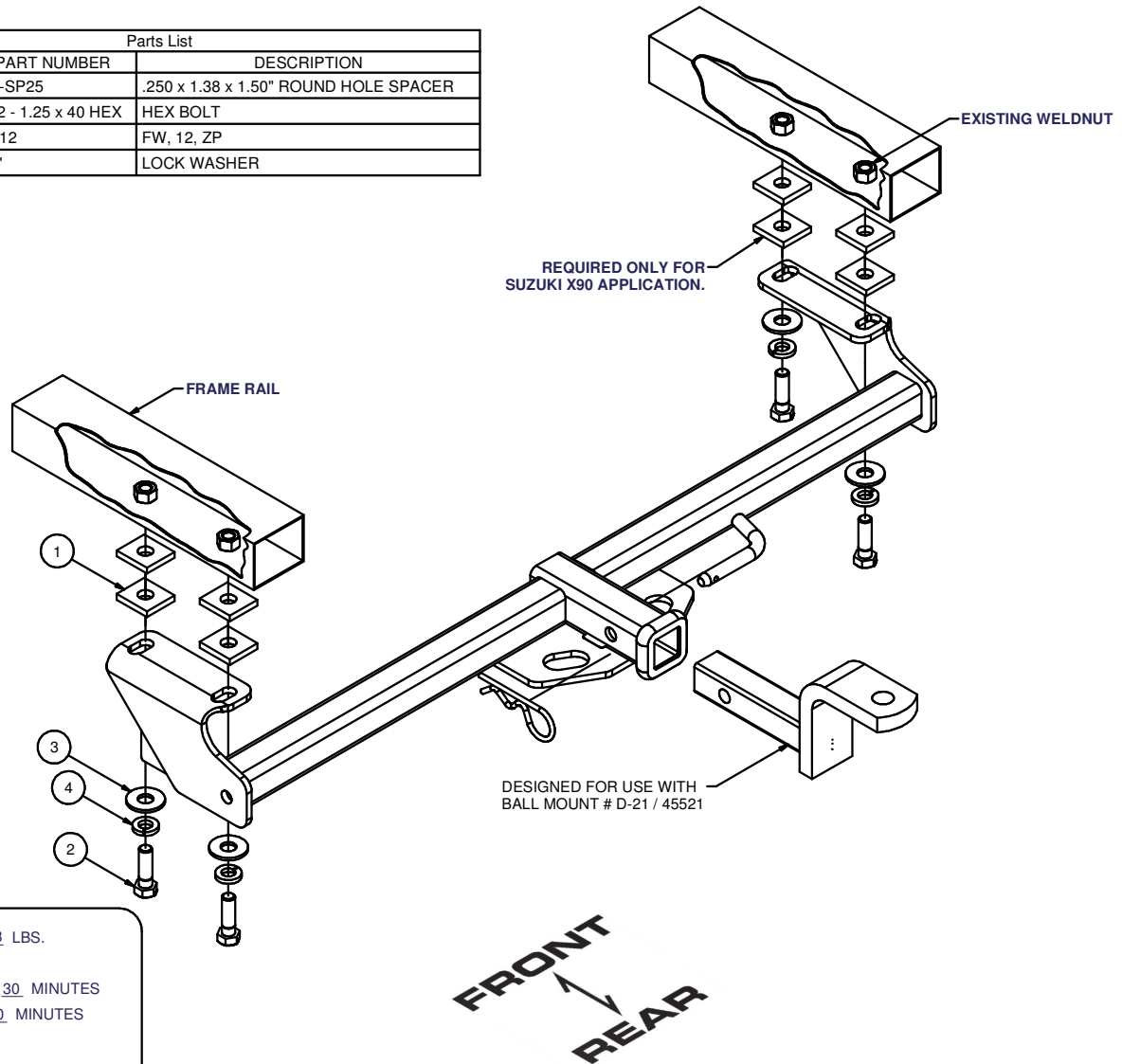

HITCH WEIGHT: 23 LBS.

INSTALL TIME

PROFESSIONAL: 30 MINUTES

NOVICE (DIY): 60 MINUTES

INSTALL NOTES:

NO DRILLING REQUIRED

INSTALLATION STEPS

- 1) If present, remove rear impact bar from vehicle frame, two bolts per side. Return impact bar and bolts to vehicle owner for replacement if hitch is removed.
- 2) Position hitch under vehicle and install fasteners as shown.
- 3) For Suzuki X90 applications, place spacers between hitch and frame to clear tow hook on passenger side as shown.
- 4) Torque all M12 fasteners to 86 lb.-ft.

PERIODICALLY CHECK THIS RECEIVER HITCH TO ENSURE THAT ALL FASTENERS ARE TIGHT AND THAT ALL STRUCTURAL COMPONENTS ARE SOUND.

Curt Manufacturing Inc., warrants this product to be free of defects in material and/or workmanship at the time of retail purchase by the original purchaser. If the product is found to be defective, Curt Manufacturing Inc., may repair or replace the product, at their option, when the product is returned, prepaid, with proof of purchase. Alteration to, misuse of, or improper installation of this product voids the warranty. Curt Manufacturing Inc.'s liability is limited to repair or replacement of products found to be defective, and specifically excludes liability for incidental or consequential loss or damage.