

INSTALLATION MANUAL

ENT00231

Level of Difficulty

Moderate

Installation difficulty levels are based on time and effort involved and may vary depending on the installer level of expertise, condition of the vehicle and proper tools and equipment.

Weight Carrying Capacity

Gross trailer weight (GTW)	6,000 lbs.
Tongue weight (TW)	900 lbs.

Weight Distribution Capacity

Weight distribution (WD)	8,000 lbs.
WD tongue weight (WDTW)	900 lbs.

Parts List

Item	Qty	Description
1	6	Hex bolt, M12-1.25 x 35mm, CL 10.9
2	6	Conical-toothed washer, 1/2"

Tools Required

Ratchet	Torque wrench
Socket, 1/2"	Socket extension, 6"
Socket, 10mm	Screwdriver
Socket, 17mm	Rotary tool (optional)
Socket, 19mm	Safety glasses

⚠ WARNING

Never exceed the vehicle manufacturer's recommended towing capacity.

Product Photo



NOTICE

Before you begin installation, read all instructions thoroughly.

Proper tools will improve the quality of installation and reduce the time required.

This installation requires part removal and removal / trimming of the fascia and underbody panels. No drilling is required.

Periodic inspection of the trailer hitch should be performed to ensure all mounting hardware remains tight and structural components are secure.

To help prevent damage to the product or vehicle, refer to the specified torque specifications when securing hardware during the installation process.

SAFETY INSTRUCTIONS

Safety glasses should be worn at all times while installing this product.

Warranty Information

Our products are backed by industry-leading warranties. For a copy of the product warranties or to provide feedback, please contact our support line using the phone number at the bottom of this document.

ASSEMBLY

Parts List

Item	Qty	Description
1	6	Hex bolt, M12-1.25 x 35mm, CL 10.9
2	6	Conical-toothed washer, 1/2"

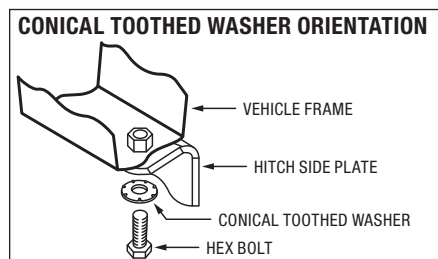
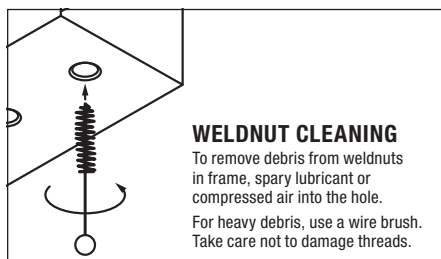
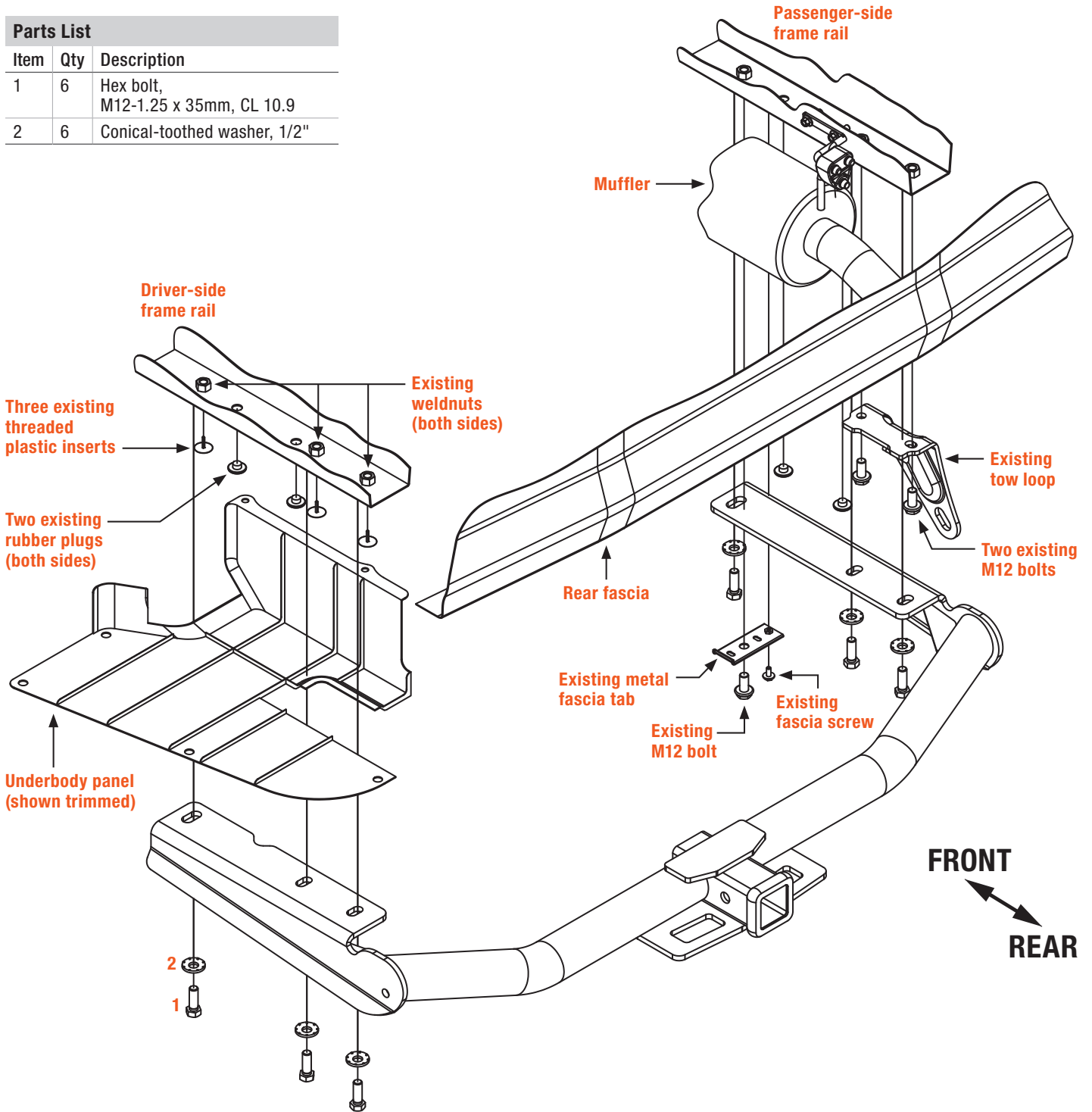

Step 1

Remove the seven fasteners securing the driver-side underbody panel. After lowering the underbody panel return it to the owner or trim and reinstall in Step 5.

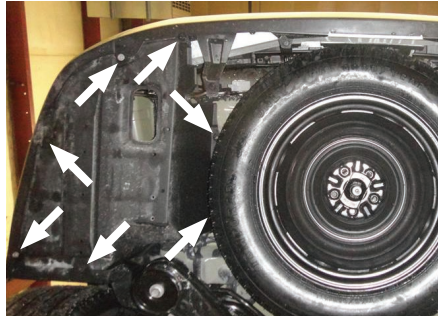

Step 2

Remove the two rubber plugs from each of the frame rails. Unscrew the three threaded plastic inserts from the driver-side frame rail. Return the plugs and inserts to the owner.

Mark the lower fascia exhaust air deflector 2" from the 'hinge'. Trim as shown to allow room for the hitch.



Step 3

Remove the three M12 bolts securing the metal fascia tab and tow loop to the passenger-side frame rail.

Remove the single fascia screw and metal fascia tab from the passenger-side underbody panel.

Return the fascia tab, tow loop and fasteners to the owner.



Step 4

Raise the hitch over the exhaust and align the holes in the hitch with the weldnuts in the frame. Secure the hitch to the frame using the provided M12-1.25 hex bolts (#1) and 1/2" conical-toothed washers (#2).

Torque all M12 hardware to 86 ft-lbs.



Step 5

Mark and trim the underbody panel. See the trim diagram for reference. Dimensions are approximate. Confirm fit prior to trimming. Use the ribs of the underbody panel as cutting guides.

Reattach the underbody panel using the fasteners removed in Step 1.

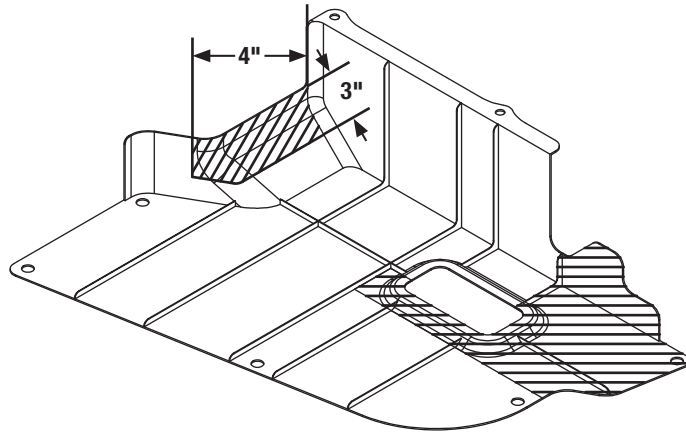

Final Installed Image

