

THIS KIT DOES NOT REQUIRE DRILLING INTO THE FRAME.

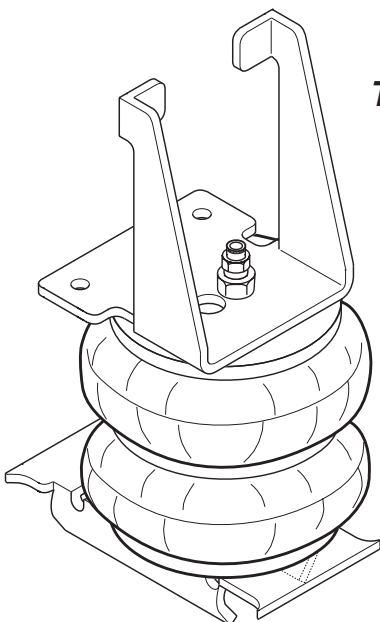

INSTALLATION INSTRUCTIONS

Congratulations - your new Air Helper Springs are quality products capable of improving the handling and comfort of your vehicle. As with all products, proper installation is the key to obtaining all of the benefits your kit is capable of delivering. Please take a few minutes to read through the instructions to identify the components and learn where and how they are used. It is a good idea to start by comparing the parts in your kit with the parts list below.

The heart of the air spring kit is, of course, the air helper springs. Remember that the air helper springs must flex and expand during operation, so be sure that there is enough clearance to do so without rubbing against any other part of the vehicle.

Be sure to take all applicable safety precautions during the installation of the kit. The instructions listed in this brochure and the illustrations all show the left, or driver's side of the vehicle. To install the right side assembly simply follow the same procedures.

WARNING:

Do not inflate this assembly when it is unrestricted. The assembly must be restricted by the suspension or other adequate structure. Do not inflate beyond 100 psi. Improper use or over inflation may cause property damage or severe personal injury.

This kit includes inflation valves and air lines for each air spring. This will allow you to compensate for unbalanced loads. If you would rather have a single inflation valve system to provide equal pressure to both air springs, your dealer can supply the optional "T" fitting.

IMPORTANT!

For your safety and to prevent possible damage to your vehicle, do not exceed the maximum load recommended by the vehicle manufacturer (GVWR). Although your Air Helper Springs are rated at a maximum inflation pressure of 100 psi, this pressure may allow you to carry too great a load on some vehicles. It is best to have your vehicle weighed once it is completely loaded and compare that weight to the maximum allowed. Check your vehicle owner's manual or data plate on driver side door for maximum loads listed for your vehicle.

When inflating your Air Helper Springs, add air pressure in small quantities, checking pressure frequently during inflation. The air spring requires much less air volume than a tire and, therefore, inflates much quicker.

PARTS LIST

AIR SPRING	6401	2	3/8"-16 BAIL CLAMP	3292	2
UPPER BRACKET	5369	2	5/16" FLAT WASHER		4
LOWER BRACKET	5370	2	3/8"-16 X 3/4" FLANGE LOCK		2
AXLE BRACKET	5181	2	3/8"-16 FLANGE NUT		4
HEAT SHIELD	1004	1	3/4"-16 HEX NUT		2
22 ft. TUBING	0937	1	3/4" STAR WASHER		2
INFLATION VALVE	3032	2	10MM X 30MM FLAT HEAD BOLT		4
MALE CONNECTOR	3046	2	NYLON TIE WRAP		6
THERMAL SLEEVE	0899	2	CAUTION TAG		2

FIGURE "A"

NOTE: Both illustrations are of the left, or drivers side, of the vehicle. Reverse any orientations when assembling and installing the right, or passenger, side of the vehicle.

NOTE: 4X4 SHOWN, USE SAME PROCEDURES ON 2WD. THE JOUNCE BUMPER BRACE ON 4WD WILL NOT INTERFERE WITH INSTALLATION.

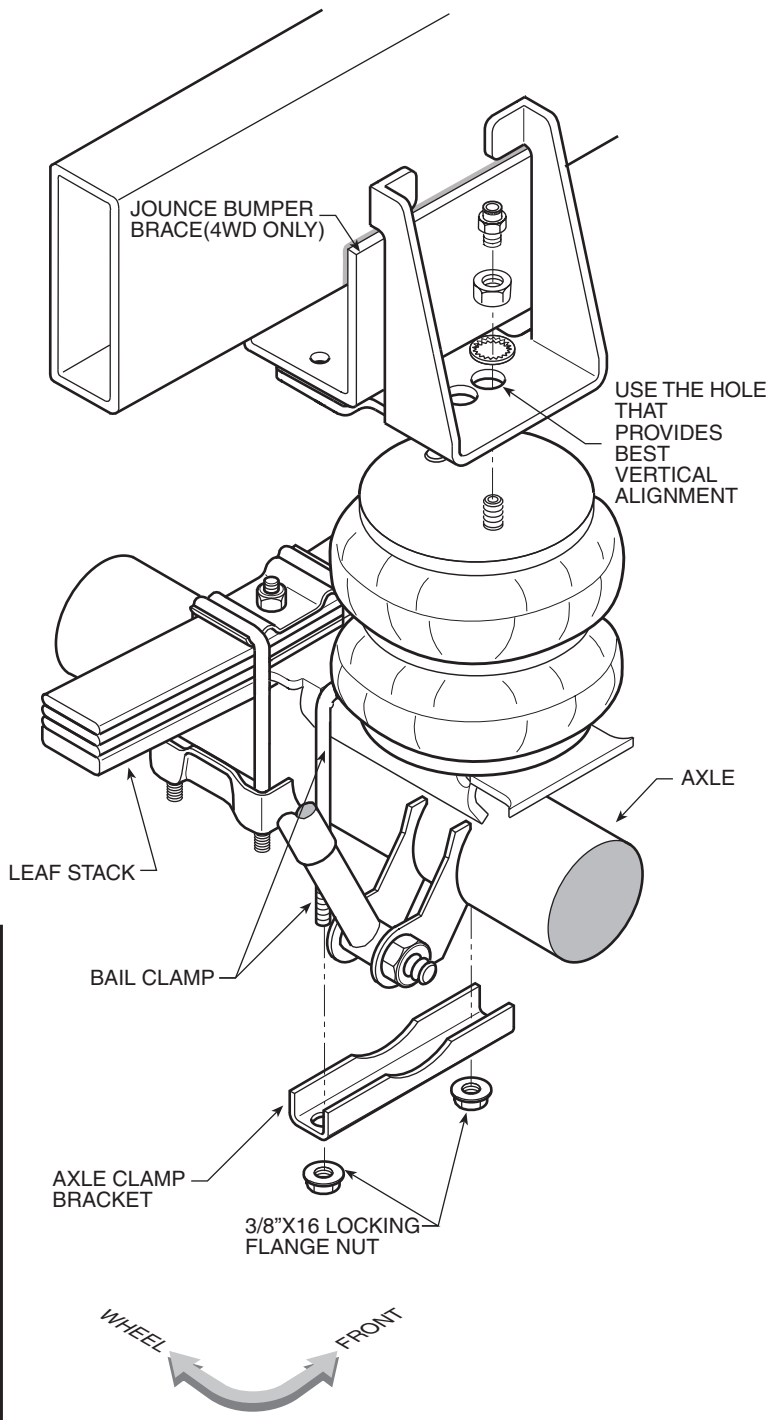

KIT ASSEMBLY

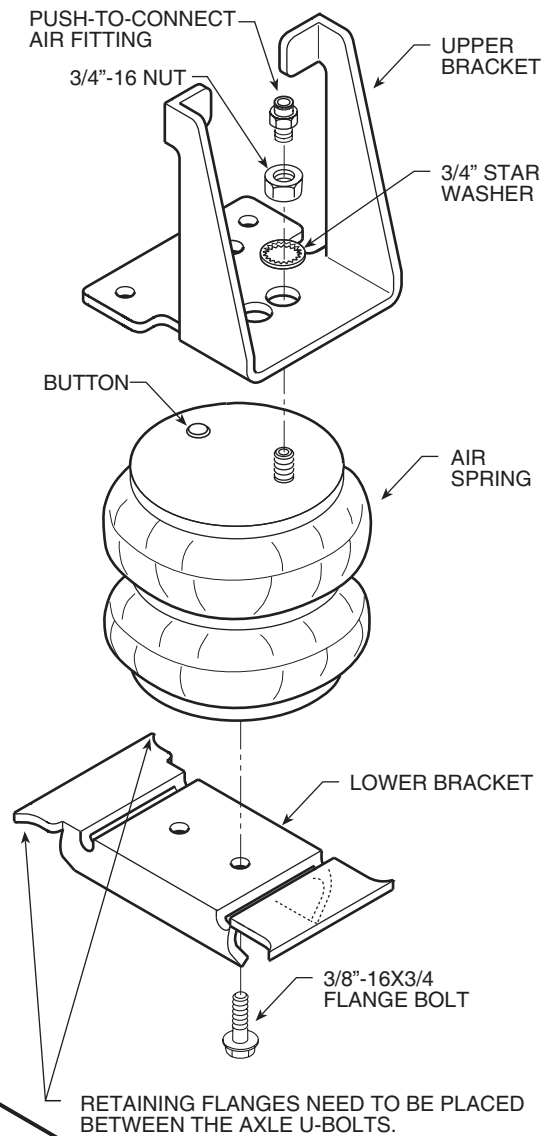

Lower Bracket Orientation

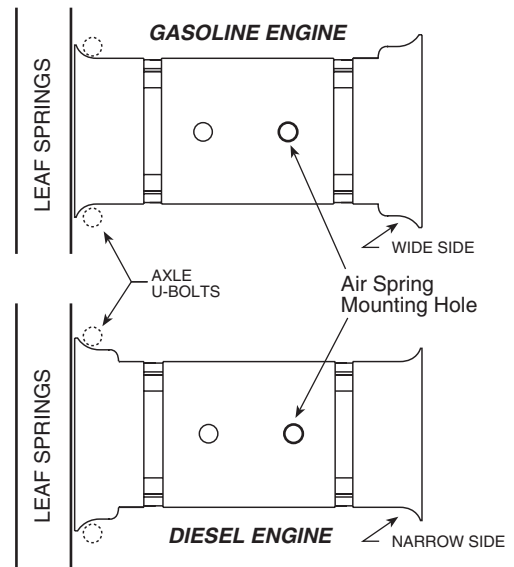

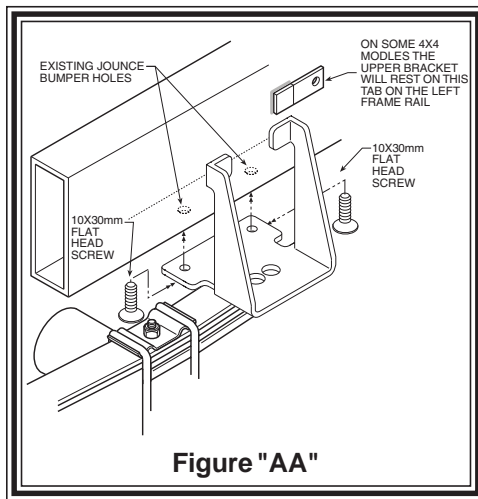

Figure "AA"

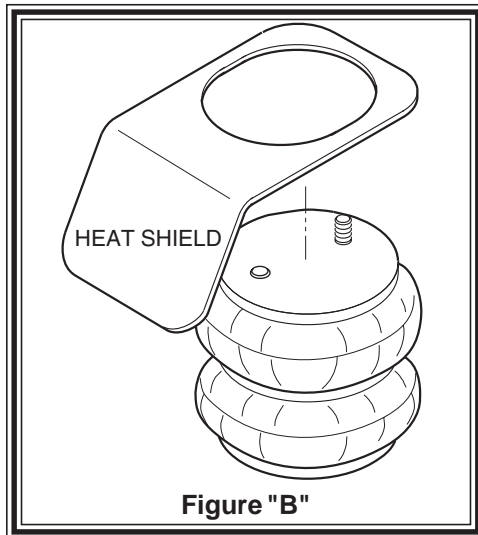

Figure "B"

NOTE:

Please read through this manual completely before installing the air spring kit to your vehicle.

STEP 1 - PREPARE THE VEHICLE

With the vehicle on a solid, level surface chock the front wheels. Remove the negative battery cable. Your vehicle is equipped with rubber jounce bumpers. The jounce bumpers are bolted to the frame above the axle. Remove the jounce bumpers from the vehicle.

STEP 2 - PRE-ASSEMBLE THE KIT

Select a lower bracket from your kit and determine which side of the bracket fits most snugly between the axle U-bolts as shown in *Figure "A"*. **NOTE: The two different widths on the ends of the bracket.** It will be necessary to tilt the bracket to properly slide the brackets retaining flange between the U-bolts and the leaf stack. Remove the bracket from the axle and mark which side fit between the U-bolts. Select one air spring from the kit and install the air spring to the lower bracket with one 3/8-16 X 3/4" flange head bolt finger tight, *see Figure "A"*. Next, install the male fitting into the air inlet in the combo stud of the air spring. Tighten the air fitting securely to engage the orange thread sealant.

STEP 3 - INSTALLING THE ASSEMBLY TO THE VEHICLE

Select an upper bracket from the kit and install it in place of the jounce bumper using two 10mm X 30mm flat head screws tightened securely, *see Figure "AA"*. The 2wd and the 4X4 mount in the same fashion. The 2wd will mount directly to the frame. The 4X4 will mount to the jounce bumper brace. Position the lower bracket and air spring assembly from Step 2 on the axle as shown in *Figure "A"*. Make sure the large threaded stud and the button on the top of the air spring protrudes **through the holes that provide the best vertical alignment** of the air spring. Tighten the 3/8"-16 flange bolt on the lower bracket from step 2. Fasten the lower bracket to the axle housing using the bail clamp and the axle clamp bracket and two 3/8"-16 locking flange nuts securely, *see Figure "A"*. The bail clamp

should fit in the locating notches in the lower bracket. Attach the top of the air spring with the 3/4-16 hex nut and 3/4" star washer. You must maintain a minimum of 1/2" clearance around the air spring for proper operation. Once the bracket orientation has been set, tighten the 3/8"-16x3/4" hex head bolt in the lower bracket securely.

STEP 4 - INSTALLATION OF THE PASSENGER'S SIDE ASSEMBLY

Follow steps 1-3 with reverse orientations for assembly and installation of the passenger's side assembly. The heat shield is mounted between the upper bracket and the top plate of the air spring, *see Figure "B"*. Position the heat shield directly between the closest heat source and the air spring. Ensure that the heat shield will not interfere with normal operation of the air spring or the vehicle's suspension. Do not position the heat shield directly above the axle, as it may contact the axle on full suspension travel.

STEP 5 - INSTALL THE AIR LINE AND INFLATION VALVE

Uncoil the airline tubing and cut it into two equal lengths. **DO NOT FOLD OR KINK THE AIRLINE TUBING.** Try to make the cut as square as possible. Insert one end of the airline tubing into the air fitting installed in the top of the air helper spring. Push the airline tubing into the fitting as far as possible, *see Figure "A"*.

Select a location on the vehicle for the air inflation valves. The location can be on the bumper or the body of the vehicle, as long as it is in a protected location so the valve will not be damaged, but maintain accessibility for the air chuck, *see Figure "C"*. Drill a 5/16" hole and install the air inflation valve using two 5/16" flat washers per valve as supports, *see Figure "D"*. Run the airline tubing from the air helper spring to the valve, routing it to avoid direct heat from the engine, exhaust pipe, and away from sharp edges. Thermal sleeves have been provided for these conditions. The airline tubing should not be bent or curved sharply as it may buckle. Secure the airline tubing in place with the nylon ties provided. Push the end of the airline tubing into the inflation valve as illustrated, *see Figure "D"*.

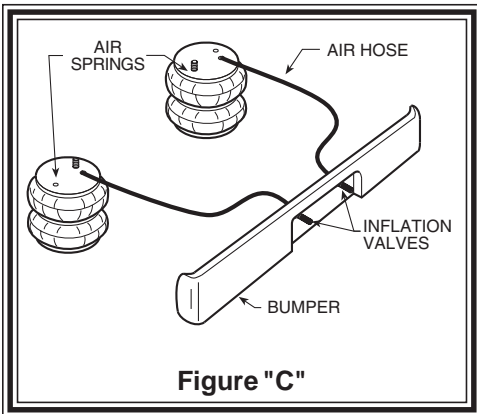

Figure "C"

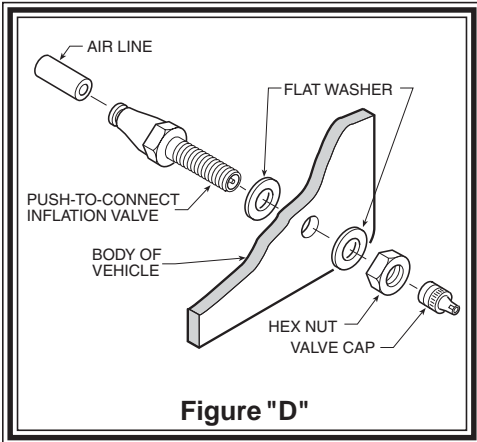

Figure "D"

STEP 6 - CHECK THE AIR SYSTEM

Once the inflation valves are installed, inflate the air helper springs to 70 psi and check the fittings for air leaks. Using a spray bottle, apply a solution of soap and water to the fittings. If a leak is detected at a airline tubing connection then check to make sure that the airline tube is cut as square as possible and that it is pushed completely into the fitting. The airline tubing can easily be removed from the fittings by exhausting all the pressure in the air springs and then pushing the collar towards the body of the fitting and then, with a pull, remove the airline tubing. Re-install the tubing and reinflate the air springs and check for leaks as noted above. If a leak is detected where the air fitting screws into the spring, just screw the air fitting into the air spring until the leak stops.

This now completes the installation. Reattach the negative battery cable and remove the wheel chocks from the front wheels. Before proceeding, check once again to be sure you have proper clearance around the air springs. With a load on your vehicle and the air helper springs inflated, you must have at least 1/2" clearance around the air springs. As a general rule, the air helper springs will support approximately 50 lbs. of load for each psi of inflation pressure (per pair). For example, 50 psi of inflation pressure will support a load of 2500 lbs. per pair of air helper springs. *FOR BEST RIDE* use only enough air pressure in the air helper springs to level the vehicle when viewed from the side (front to rear). This amount will vary depending on the load, location of load, condition of existing suspension and personal preference.

NOTE:

Too much air pressure in the air helper springs will result in a firmer ride, while too little air pressure will allow the air helper spring to bottom out over rough conditions. Too little air pressure will not provide the improvement in handling that is possible. **TOPREVENTPOSSIBLEDAMAGEMAINTAINAMINIMUM OF 5 psi IN THE AIR HELPER SPRINGS AT ALL TIMES.**

NOTE:

MIN PRESSURE	5PSI
MAX PRESSURE (LOADED)	100PSI

NOTE:

Once the air helper springs are installed, it is recommended that the vehicle not be lifted by the frame, as over-extension may occur, resulting in damage to the air helper springs. However, should it become necessary to raise the vehicle by the frame, deflate both air helper springs completely.

