

AT-9208FS

EXHAUST ASSEMBLY, TURBO-BACK
2017 AND UP CAN-AM MAVERICK
TURBO/TURBO R

MBRP®

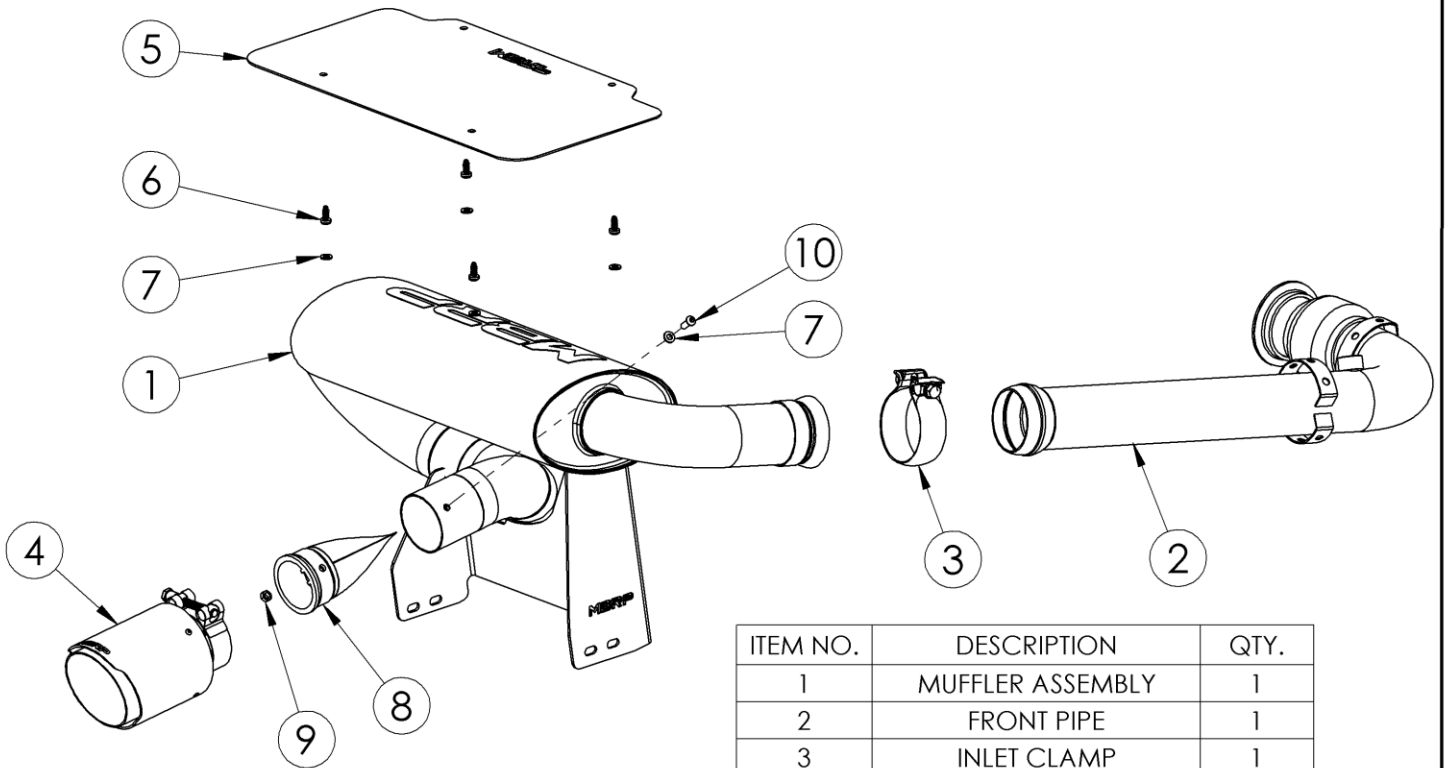

ITEMS 8, 9, & 10 ARE PRE-ASSEMBLED TO MUFFLER

ITEM NO.	DESCRIPTION	QTY.
1	MUFFLER ASSEMBLY	1
2	FRONT PIPE	1
3	INLET CLAMP	1
4	TIP	1
5	HEAT SHIELD	1
6	TAPPING SCREW	4
7	LOCK WASHER	5
8	SPARK ARRESTOR	1
9	NUT	1
10	SCREW	1

PLEASE READ BEFORE STARTING INSTALLATION

While MBRP Ltd. has made every effort to ensure that all components of this system are of superior quality and properly packaged, it is the installer's responsibility to ensure the following before removal of the factory exhaust:

- that ALL components shown above are present.
- that ALL mating components fit together.
- that there are no damaged components.
- that the system you have purchased is appropriate for your vehicle year, model and configuration.
- that the system will not interfere with any modifications previously installed or planned.
- that you have read and understand these instructions.

If you have any questions or are uncertain about any aspect of the installation of this system to your vehicle please contact your dealer before commencing installation.

MBRP

Removal of Stock Exhaust:



Figure 1



Figure 2



Figure 3



Figure 4

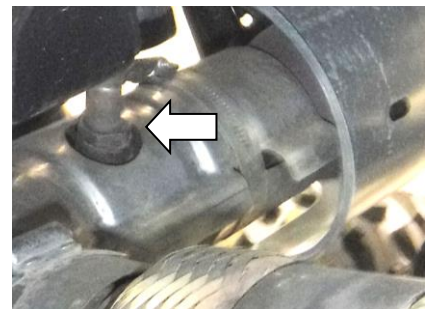

Figure 5



Figure 6

1. Remove the rear fascia assembly by removing the five (5) screws securing it. **Refer to Figure 1.**

2. Remove the two (2) bolts and nuts securing the driver-side bracket of the stock muffler. Keep the hardware as it will be reused.

3. Remove the two (2) nuts from the bolts securing the passenger-side bracket of the stock muffler. Leave the bolts in place to support the muffler. Retain the hardware as it will be reused. **Refer to Figure 2.**

4. Remove the factory springs (4) from the muffler inlet. **Refer to Figure 3.**

5. Remove the two (2) bolts from the passenger-side bracket of the stock muffler and remove the muffler.

6. Remove the panel between the driver and passenger seats to access the turbo outlet. **Refer to Figure 4.**

7. Disconnect the O2 sensor wiring and then remove the sensor from the stock front pipe. **Refer to Figure 5.**

8. Remove the band clamps (loosen them until they open) from the heat shields on the stock front pipe and then remove the shields – they will be reused. **Refer to Figure 6.**

9. Loosen the v-band clamp (it has a heat shield attached to it) on the turbo outlet until the nut comes off (do not discard); this will allow it to fully open. **Refer to Figure 7.**

10. With the v-band clamp fully opened, slide it off of the turbo flange and onto the front pipe. **Refer to Figure 8.** Remove the front pipe from the turbo and out from the vehicle.

Installation of MBRP Exhaust:

1. Remove the thin steel gasket from the inlet flange on the stock pipe and place it onto the inlet flange of the **Front Pipe**.

2. Fully open the v-band clamp and place it over the turbo flange, then place the **Front Pipe** into position with the flange mated to the turbo outlet. Seat the clamp over the **Front Pipe** flange and the turbo flange, then replace the nut and tighten the clamp to hold the **Front Pipe** in place. Do not fully tighten the v-band clamp yet.

3. Assemble the heat shields onto the **Front Pipe**, reusing the stock band clamps. Note that the front band clamp must slide through the opening on the vehicle bracket, as it holds both the heat shield and pipe to the bracket. The rear clamp can be fully tightened, but leave the front clamp slightly loose.

4. Prior to installing the **Muffler Assembly**, the **Heat Shield** should be installed to the underside of the rear deck. Align the **Heat Shield** holes with the four (4) cylindrical bosses centered on the underside of the rear deck, then install the **Tapping Screws** (4) with **Lock Washers** (4). Ensure that the bosses are cleared of dirt prior to installing the **Tapping Screws**.

5. Place the **Muffler Assembly** into position and insert the previously removed long stock bolts through the passenger-side holes of the mounting bracket and into the stock mounts, loosely securing them using the stock nuts.

MBRP



Figure 7



Figure 8



Figure 9



Figure 10

6. With the passenger-side mounting hardware in place, insert the driver-side bolts through the mounting holes and loosely secure them with the stock nuts to hold the **Muffler Assembly** in place.

7. Loosen the **Inlet Clamp** and place it over the end of the **Front Pipe**.

8. Place the **Muffler Assembly** inlet into position over the **Front Pipe** ball flare and secure it loosely using the **Inlet Clamp**. If necessary, adjust the position of the **Front Pipe** by rotating (up/down) the pipe about the turbo flange connection. Once the **Front Pipe** is aligned with the **Muffler Assembly** inlet, fully tighten the v-band clamp at the turbo, and then tighten the **Inlet Clamp**. Ensure that the heat shield attached to the v-band clamp is directed towards the top and front of the vehicle as it was originally.

9. With the **Muffler Assembly** positioned appropriately, fully tighten the mounting bolts (4) and nuts (4).

10. Fully tighten the front band clamp to the front pipe heat shields and vehicle bracket.

11. Reinstall the O2 sensor into the bung on the **Front Pipe** and reconnect the wiring.

12. In order to install the **Tip**, the **Screw** (and **Lock Washer**) securing the **Spark Arrestor** inside the outlet must be removed temporarily. Be careful not to lose the **Nut** on the inside of the **Spark Arrestor**, as it may fall out when the **Screw** is removed.

With the **Screw** removed, slide the **Tip** over the **Muffler Assembly** outlet and line up the hole with the screw hole in the outlet. Holding the **Nut** and **Spark Arrestor** in place (re-align the **Nut** with the hole if necessary), reinstall the **Washer** and **Screw**. Refer to Figures 9 & 10.

13. Finally, reinstall the rear fascia assembly and replace the panel between the driver and passenger seats.



Heat reflective tape is provided for the frame area that is close to the bend of the muffler outlet pipe. Use if desired to protect the paint.

It is recommended that the hardware be retightened after the first ride and checked periodically thereafter, tightening if necessary.

In order to maintain optimal performance, the spark arrestor screen should be cleaned after every 30-35 hours of use.

Congratulations! You are ready to begin experiencing the improved performance and driving excitement of your MBRP Ltd. Exhaust upgrade. We know you will enjoy your purchase.