

# S5003

2020-UP CHEV/GMC SILVERADO/SIERRA  
1500, 6.2L - WITH SINGLE EXHAUST VALVE -  
3" MUFFLER BYPASS

# MBRP®

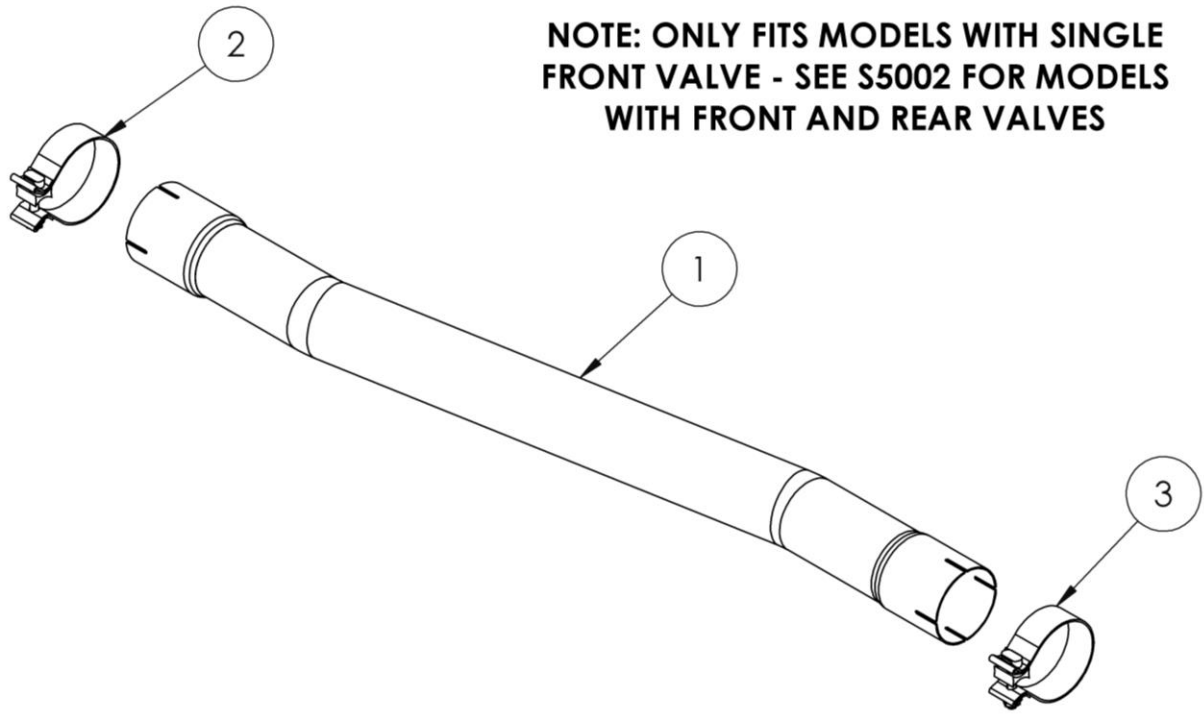

**NOTE: ONLY FITS MODELS WITH SINGLE  
FRONT VALVE - SEE S5002 FOR MODELS  
WITH FRONT AND REAR VALVES**

ITEM	DESCRIPTION	QTY.
1	MUFFLER BYPASS PIPE	1
2	3.2" BAND CLAMP	1
3	3.0" CLAMP	1

## PLEASE READ BEFORE STARTING INSTALLATION

While MBRP has made every effort to ensure that all components of this system are of superior quality and properly packaged, it is the installer's responsibility to ensure the following before removal of the factory exhaust:

- that ALL components shown above are present.
- that ALL mating components fit together.
- that there are no damaged components.
- that the system you have purchased is appropriate for your vehicle year, model and configuration.
- that the system will not interfere with any modifications previously installed or planned.
- that you have read and understand these instructions.

If you have any questions or are uncertain about any aspect of the installation of this system to your vehicle please contact your dealer before commencing installation.

# MBRP

## Removal of Stock System

**NOTE: Only fits models with single front valve.**

**Refer to Figure 1.**



**Figure 1.**

1. Mark cut lines on the OEM exhaust as close to the muffler as possible on the inlet side, and approximately 5" from the face of the muffler on the outlet side.

**Refer to Figure 2.**

2. Support the Muffler and cut on previously marked lines to remove the muffler from the vehicle.

## Installation of MBRP Performance Exhaust

1. Install the **3.2" Band Clamp** and **3.0" Band Clamp** onto the respective ends of the **Muffler Bypass Pipe**.

2. Install the 3.2" expansion side of the **Muffler Bypass Pipe** over the front section of the OEM exhaust first. Carefully push the rear section of the OEM exhaust towards the rear of the vehicle to line up the **Muffler Bypass Pipe**.

**Refer to Figures 3 and 4.**

3. Once aligned, pull the rear section of OEM exhaust forward to fully seat into the expansions of the **Muffler Bypass Pipe**. Adjust the rotation of the pipe so that the outlet sits slightly higher than the inlet side. Reference the OEM Muffler for alignment.

**Refer to Figure 5.**

4. Align the edge of each band clamp with the edge of the joint it is connecting. Tighten all hardware and clamps, starting at the front and working rearward to secure the system. Check along the full length of the exhaust system to ensure there is adequate clearance for fuel lines, vent lines, brake lines, frame, bodywork, suspension, and any wiring, etc. If there is any interference detected, relocate, or adjust to provide adequate clearance. Ensure all clamp connections are secure and components are unable to rotate or slide. Band clamps require approximately 45 lb-ft (60 Nm) of torque. Verify clearances, system security and band clamp torque after 30-60 miles (50-100 km) of driving.



**Figure 2**



**Figure 3**



**Figure 4**



**Figure 5**

**Congratulations!** You are ready to begin experiencing the improved power, sound and driving excitement of your **MBRP** Performance Exhaust system. We know you will enjoy your purchase.